

Date: **April 10, 2025**



Telamon
319 Chapanoke Road, Suite 118
Raleigh, NC 27603
(405) 348-5460

Subject: **Structural Analysis Report**

Carrier Designation: **Verizon Wireless Co-Locate**
Site Number: 5000252968
Site Name: CANO NOVATO III

Crown Castle Designation: **BU Number:** 815558
Site Name: NOVATO
JDE Job Number: 2135518
Work Order Number: 2377876
Order Number: 690637 Rev. 0

Engineering Firm Designation: **Telamon Project Number:** 42285-815558-2377876-01-STR

Site Data: **615 Atherton Ave, Novato, Marin County, CA**
Latitude 38° 6' 45.71", Longitude -122° 32' 58.92"
65.9 Foot - Monopole Tower

Telamon is pleased to submit this “**Structural Analysis Report**” to determine the structural integrity of the above mentioned tower.

The purpose of the analysis is to determine acceptability of the tower stress level. Based on our analysis we have determined the tower stress level for the structure and foundation, under the following load case, to be:

LC7: Proposed Equipment Configuration

Sufficient Capacity

This analysis has been performed in accordance with the 2022 California Building Code based upon an ultimate 3-second gust wind speed of 92 mph. Applicable Standard references and design criteria are listed in Section 2 - Analysis Criteria.

Structural analysis prepared by: Shubham Dhamdhare

Respectfully submitted by:

Brandon T. Compton, P.E., S.E.
Structural Engineer



TABLE OF CONTENTS

1) INTRODUCTION

2) ANALYSIS CRITERIA

Table 1 - Proposed Equipment Configuration
Table 2 - Other Considered Equipment

3) ANALYSIS PROCEDURE

Table 3 - Documents Provided
3.1) Analysis Method
3.2) Assumptions

4) ANALYSIS RESULTS

Table 4 - Section Capacity (Summary)
Table 5 - Tower Component Stresses vs. Capacity - LC7
4.1) Recommendations

5) APPENDIX A

tnxTower Output

6) APPENDIX B

Base Level Drawing

7) APPENDIX C

Additional Calculations

1) INTRODUCTION

This tower is a 65.9 ft Monopole tower designed by FDH Engineering.

2) ANALYSIS CRITERIA

TIA-222 Revision:	TIA-222-H
Risk Category:	II
Wind Speed:	92 mph
Exposure Category:	B
Topographic Factor:	2.091
Seismic Ss:	1.5
Seismic S1:	0.6
Service Wind Speed:	60 mph

Table 1 - Proposed Equipment Configuration

Mounting Level (ft)	Center Line Elevation (ft)	Number of Antennas	Antenna Manufacturer	Antenna Model	Number of Feed Lines	Feed Line Size (in)
61.0	65.0	3	ericsson	AIR 6449 B77D_CCIV3 w/ Mount Pipe	20 2	7/8 1-1/4
	63.0	4	cambridge broadband networks group	39GHz VectaStar w/ Mount Pipe		
		12	commscope	CBC1923T-DS-43		
		4	commscope	NHH-33B-R2B w/ Mount Pipe		
		6	ericsson	4449		
		8	ericsson	8843		
		2	matsing	MS-MBA-3.2-H4-L4 w/ Mount Pipe		
	2	raycap	RCMDC-3315-PF-48			
61.0	8	tower mounts	T-Arm Mount [TA 601-1]			

Table 2 - Other Considered Equipment

Mounting Level (ft)	Center Line Elevation (ft)	Number of Antennas	Antenna Manufacturer	Antenna Model	Number of Feed Lines	Feed Line Size (in)
56.0	56.0	1	tower mounts	Side Arm Mount [SO 102-3]	2	7/8
	55.0	1	kathrein	742 215 w/ Mount Pipe		
49.0	49.0	1	commscope	MC-PK8-DSH Platform Mount	1	1-3/8
		3	fujitsu	TA08025-B604		
		3	fujitsu	TA08025-B605		
		3	jma wireless	MX08FRO665-21		
		1	raycap	RDIDC-9181-PF-48		
39.0	39.0	1	site pro 1	RMV12-396 Triple T-Arm Mount	8	1/4
		8	mikrotik	NETMETAL AC2		
		4	ubiquiti network	AM-5G19-120 w/ Mount Pipe		
		4	ubiquiti network	RD-5G30		

Mounting Level (ft)	Center Line Elevation (ft)	Number of Antennas	Antenna Manufacturer	Antenna Model	Number of Feed Lines	Feed Line Size (in)
19.0	20.0	1	kathrein	742 215 w/ Mount Pipe	13 4	1/2 7/8
	19.0	1	kathrein	742 215 w/ Mount Pipe		
		1	tower mounts	Side Arm Mount [SO 102-3]		

3) ANALYSIS PROCEDURE

Table 3 - Documents Provided

Document	Reference	Source
4-GEOTECHNICAL REPORTS	1011316	CCISITES
4-TOWER MANUFACTURER DRAWINGS	2327964	CCISITES
4-TOWER FOUNDATION DRAWINGS/DESIGN/SPECS	2336358	CCISITES

3.1) Analysis Method

tnxTower (version 8.3.0.5), a commercially available analysis software package, was used to create a three-dimensional model of the tower and calculate member stresses for various loading cases. Selected output from the analysis is included in Appendix A. When applicable, Crown Castle has calculated and provided the effective area for panel antennas using approved methods following the intent of the TIA-222 standard.

3.2) Assumptions

- 1) Tower and structures were maintained in accordance with the TIA-222 Standard.
- 2) The configuration of antennas, transmission cables, mounts and other appurtenances are as specified in Tables 1 and 2 and the referenced drawings.

This analysis may be affected if any assumptions are not valid or have been made in error. Telamon should be notified to determine the effect on the structural integrity of the tower.

4) ANALYSIS RESULTS

Table 4 - Section Capacity (Summary)

Section No.	Elevation (ft)	Component Type	Size	Critical Element	P (K)	SF*P_allow (K)	% Capacity	Pass / Fail
L1	65.9 - 31.7	Pole	TP25.487x19x0.25	1	-12.403	1218.011	30.8	Pass
L2	31.7 - 0	Pole	TP31x24.383x0.313	2	-17.595	1896.762	45.0	Pass
							Summary	
						Pole (L2)	45.0	Pass
						Rating =	45.0	Pass

Table 5 - Tower Component Stresses vs. Capacity - LC7

Notes	Component	Elevation (ft)	% Capacity	Pass / Fail
1	Anchor Rods	0	72.5	Pass
1	Base Plate	0	77.2	Pass
1	Base Foundation (Structure)	0	50.5	Pass
1	Base Foundation (Soil Interaction)	0	44.6	Pass

Structure Rating (max from all components) =	77.2%
---	--------------

Notes:

- 1) See additional documentation in "Appendix C – Additional Calculations" for calculations supporting the % capacity consumed.

4.1) Recommendations

The tower and its foundation have sufficient capacity to carry the proposed load configuration. No modifications are required at this time.

APPENDIX A
TNXTOWER OUTPUT

65.9 ft

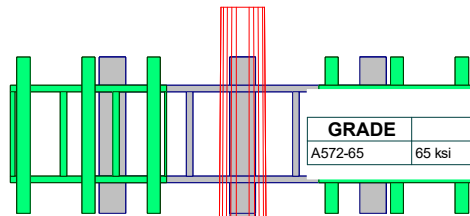

MATERIAL STRENGTH

TOWER DESIGN NOTES

1. Tower is located in Marin County, California.
2. Tower designed for Exposure B to the TIA-222-H Standard.
3. Tower designed for a 92 mph basic wind in accordance with the TIA-222-H Standard.
4. Deflections are based upon a 60 mph wind.
5. Tower Risk Category II.
6. Topographic Category 5 with Crest Height of 375.000 ft
7. CCISeismic Note: Seismic loads generated by CCISeismic 5.0.0
8. CCISeismic Note: Seismic calculations are in accordance with TIA-222-H-1
9. TOWER RATING: 45%

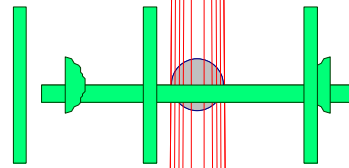
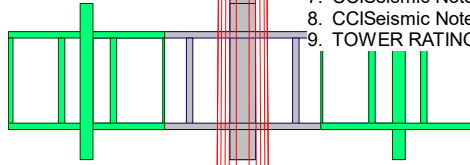

31.7 ft

0.0 ft

Section	1	2
Length (ft)	34.200	34.886
Number of Sides	12	12
Thickness (in)	0.250	0.312
Socket Length (ft)	3.186	24.383
Top Dia (in)	19.000	31.000
Bot Dia (in)	25.487	
Grade	A572-65	
Weight (K)	2.1	3.3

ALL REACTIONS ARE FACTORED

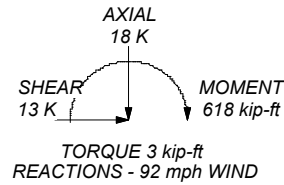
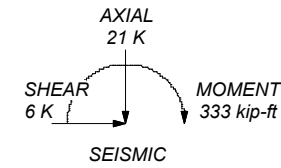

telamon 319 Chapanoke Road, Suite 118 Raleigh, NC 27603 Phone: (405) 348-5460 FAX: (405) 341-6334	Job: BU# 815558 -Novato	
	Project: 42285-815558-2377876-01-STR	
Client: Crown Castle	Drawn by: SD	App'd:
Code: TIA-222-H	Date: 04/08/25	Scale: NTS
Path:	Dwg No. E-1	

Tower Input Data

The tower is a monopole.
 This tower is designed using the TIA-222-H standard.
 The following design criteria apply:

- Tower is located in Marin County, California.
- Tower base elevation above sea level: 439.917 ft.
- Basic wind speed of 92 mph.
- Risk Category II.
- Exposure Category B.
- Crest Height: 375.000 ft.
- Rigorous Topographic Factor Procedure for wind speed-up calculations is used.
- Topographic Feature: Hill.
- Slope Distance L: 1490.000 ft.
- Distance from Crest x: 79.466 ft.
- Horizontal Distance Downwind: No.
- Deflections calculated using a wind speed of 60 mph.
- CCISEismic Note: Seismic loads generated by CCISEismic 5.0.0.
- CCISEismic Note: Seismic calculations are in accordance with TIA-222-H-1.
- Non-linear (P-delta) analysis was used.
- Pressures are calculated at each section.
- Stress ratio used in pole design is 1.
- Tower analysis based on target reliabilities in accordance with Annex S.
- Load Modification Factors used: $K_{es}(F_w) = 0.95$, $K_{es}(E_v \text{ and } E_h) = 1.0$.
- Maximum demand-capacity ratio is: 1.05.
- Local bending stresses due to climbing loads, feed line supports, and appurtenance mounts are not considered.

Options

- | | | |
|--|---|---|
| Consider Moments - Legs
Consider Moments - Horizontals
Consider Moments - Diagonals
Use Moment Magnification
✓ Use Code Stress Ratios
✓ Use Code Safety Factors - Guys
Escalate Ice
Always Use Max Kz
Kz In Exposure D Hurricane Region
Include Bolts In Member Capacity
Leg Bolts Are At Top Of Section
Secondary Horizontal Braces Leg
Use Diamond Inner Bracing (4 Sided)
SR Members Have Cut Ends
SR Members Are Concentric
Distribute Leg Loads As Uniform
Use Special Wind Profile | Assume Legs Pinned
✓ Assume Rigid Index Plate
✓ Use Clear Spans For Wind Area
Use Clear Spans For KL/r
Retension Guys To Initial Tension
✓ Bypass Mast Stability Checks
✓ Use Azimuth Dish Coefficients
✓ Project Wind Area of Appurtenances
✓ Alternative Appurt. EPA Calculation
Autocalc Torque Arm Areas
Add IBC .6D+W Combination
✓ Sort Capacity Reports By Component
Triangulate Diamond Inner Bracing
Treat Feed Line Bundles As Cylinder
Ignore KL/ry For 60 Deg. Angle Legs
Use ASCE 10 X-Brace Ly Rules | Calculate Redundant Bracing Forces
Ignore Redundant Members in FEA
SR Leg Bolts Resist Compression
All Leg Panels Have Same Allowable
Offset Girt At Foundation
✓ Consider Feed Line Torque
Include Angle Block Shear Check
Use TIA-222-H Bracing Resist. Exemption
Use TIA-222-H Tension Splice Exemption
<div style="text-align: center; background-color: #e0e0e0; padding: 2px;">Poles</div> ✓ Include Shear-Torsion Interaction
Always Use Sub-Critical Flow
Use Top Mounted Sockets
Pole Without Linear Attachments
Pole With Shroud Or No Appurtenances
Outside and Inside Corner Radii Are Known |
|--|---|---|

Tapered Pole Section Geometry

Section	Elevation	Section Length	Splice Length	Number of Sides	Top Diameter	Bottom Diameter	Wall Thickness	Bend Radius	Pole Grade
	ft	ft	ft		in	in	in	in	
L1	65.900-31.700	34.200	3.186	12	19.000	25.487	0.250	1.000	A572-65 (65 ksi)
L2	31.700-0.000	34.886		12	24.383	31.000	0.312	1.250	A572-65 (65 ksi)

Tapered Pole Properties

Section	Tip Dia. in	Area in ²	I in ⁴	r in	C in	I/C in ³	J in ⁴	I/Q in ²	w in	w/t
L1	19.582	15.094	677.307	6.712	9.842	68.818	1372.408	7.429	4.422	17.688
	26.298	20.316	1651.563	9.035	13.202	125.097	3346.513	9.999	6.161	24.642
L2	25.758	24.221	1791.142	8.617	12.630	141.814	3629.340	11.921	5.697	18.231
	31.983	30.879	3711.730	10.986	16.058	231.145	7520.971	15.198	7.470	23.906

Tower Elevation	Gusset Area (per face)	Gusset Thickness	Gusset Grade	Adjust. Factor A _r	Adjust. Factor A _r	Weight Mult.	Double Angle Stitch Bolt Spacing Diagonals	Double Angle Stitch Bolt Spacing Horizontals	Double Angle Stitch Bolt Spacing Redundants
ft	ft ²	in					in	in	in
L1 65.900-31.700				1	1	1			
L2 31.700-0.000				1	1	1			

Feed Line/Linear Appurtenances - Entered As Round Or Flat

Description	Sector	Exclude From Torque Calculation	Component Type	Placement ft	Total Number	Number Per Row	Start/End Position	Width or Diameter r in	Perimeter r in	Weight klf

*49/ CU12PSM9P8XXX(1-3/8)	C	No	Surface Ar (CaAa)	49.000 - 0.000	1	1	-0.500 -0.500	1.411		0.002
*39/ CAT5E(1/4)	C	No	Surface Ar (CaAa)	39.000 - 0.000	8	4	-0.190 -0.125	0.264		0.000
LDF5-50A(7/8)	C	No	Surface Ar (CaAa)	19.000 - 0.000	4	2	0.400 0.500	1.030		0.000
LDF4-50A(1/2)	C	No	Surface Ar (CaAa)	19.000 - 0.000	4	2	0.300 0.400	0.625		0.000
*/										
Safety Line 5/8	C	No	Surface Ar (CaAa)	65.500 - 0.000	1	1	0.000 0.000	0.625		0.000

Feed Line/Linear Appurtenances - Entered As Area

Description	Face or Leg	Allow Shield	Exclude From Torque Calculation	Component Type	Placement ft	Total Number		C _A A _A ft ² /ft	Weight klf

*61/ LDF5-50A(7/8)	C	No	No	Inside Pole	61.000 - 0.000	20	No Ice	0.000	0.000
RFA1608-16S26-XXX(1-1/4)	C	No	No	Inside Pole	61.000 - 0.000	2	No Ice	0.000	0.001
*56/									
LDF5-50A(7/8)	C	No	No	Inside Pole	56.000 - 0.000	2	No Ice	0.000	0.000
*19/									
LDF4-50A(1/2)	C	No	No	Inside Pole	19.000 - 0.000	9	No Ice	0.000	0.000

Feed Line/Linear Appurtenances Section Areas

Tower Section <i>n</i>	Tower Elevation <i>ft</i>	Face	A_R	A_F	C_{AA} In Face	C_{AA} Out Face	Weight <i>K</i>
			ft^2	ft^2	ft^2	ft^2	
L1	65.900-31.700	A	0.000	0.000	0.000	0.000	0.000
		B	0.000	0.000	0.000	0.000	0.000
		C	0.000	0.000	5.324	0.000	0.331
L2	31.700-0.000	A	0.000	0.000	0.000	0.000	0.000
		B	0.000	0.000	0.000	0.000	0.000
		C	0.000	0.000	16.088	0.000	0.452

Feed Line Center of Pressure

Section	Elevation <i>ft</i>	CP_x	CP_z	CP_x Ice	CP_z Ice
		<i>in</i>	<i>in</i>	<i>in</i>	<i>in</i>
L1	65.900-31.700	0.443	0.724	0.356	0.583
L2	31.700-0.000	-0.014	1.911	-0.012	1.572

Note: For pole sections, center of pressure calculations do not consider feed line shielding.

Shielding Factor K_a

Tower Section	Feed Line Record No.	Description	Feed Line Segment Elev.	K_a No Ice	K_a Ice
L1	8	CU12PSM9P8XXX(1-3/8)	31.70 - 49.00	1.0000	1.0000
L1	10	CAT5E(1/4)	31.70 - 39.00	1.0000	1.0000
L1	16	Safety Line 5/8	31.70 - 65.50	1.0000	1.0000
L2	8	CU12PSM9P8XXX(1-3/8)	0.00 - 31.70	1.0000	1.0000
L2	10	CAT5E(1/4)	0.00 - 31.70	1.0000	1.0000
L2	13	LDF5-50A(7/8)	0.00 - 19.00	1.0000	1.0000
L2	14	LDF4-50A(1/2)	0.00 - 19.00	1.0000	1.0000
L2	16	Safety Line 5/8	0.00 - 31.70	1.0000	1.0000

User Defined Loads - Seismic

Description	Elevation <i>ft</i>	Offset From Centroid <i>ft</i>	Azimuth Angle $^\circ$	E_v	E_{hx}	E_{hz}	E_h
				<i>K</i>	<i>K</i>	<i>K</i>	<i>K</i>
CCISeismic Tower Section 1 - 1	63.800	0.000	0.000	0.053	0.000	0.000	0.153
CCISeismic Tower Section 1 - 2	56.700	0.000	0.000	0.135	0.000	0.000	0.323
CCISeismic Tower Section 1 - 3	46.700	0.000	0.000	0.147	0.000	0.000	0.260
CCISeismic Tower Section 1 - 4	36.700	0.000	0.000	0.159	0.000	0.000	0.193
CCISeismic Tower Section 2 -	32.443	0.000	0.000	0.098	0.000	0.000	0.098

Description	Elevation	Offset From Centroid	Azimuth Angle	E_v	E_{hx}	E_{hz}	E_h
	ft	ft	°	K	K	K	K
1							
CCISeismic Tower Section 2 - 2	25.000	0.000	0.000	0.213	0.000	0.000	0.141
CCISeismic Tower Section 2 - 3	15.000	0.000	0.000	0.229	0.000	0.000	0.067
CCISeismic Tower Section 2 - 4	5.000	0.000	0.000	0.244	0.000	0.000	0.013
CCISeismic kathrein 742 215 w/ Mount Pipe	56.000	0.000	0.000	0.008	0.000	0.000	0.019
CCISeismic tower mounts Side Arm Mount [SO 102-3]	56.000	0.000	0.000	0.018	0.000	0.000	0.042
CCISeismic jma wireless MX08FRO665-21	49.000	0.000	0.000	0.020	0.000	0.000	0.038
CCISeismic jma wireless MX08FRO665-21	49.000	0.000	0.000	0.020	0.000	0.000	0.038
CCISeismic jma wireless MX08FRO665-21	49.000	0.000	0.000	0.020	0.000	0.000	0.038
CCISeismic fujitsu TA08025-B604	49.000	0.000	0.000	0.015	0.000	0.000	0.029
CCISeismic fujitsu TA08025-B604	49.000	0.000	0.000	0.015	0.000	0.000	0.029
CCISeismic fujitsu TA08025-B604	49.000	0.000	0.000	0.015	0.000	0.000	0.029
CCISeismic raycap RDIDC-9181-PF-48	49.000	0.000	0.000	0.005	0.000	0.000	0.010
CCISeismic fujitsu TA08025-B605	49.000	0.000	0.000	0.018	0.000	0.000	0.034
CCISeismic fujitsu TA08025-B605	49.000	0.000	0.000	0.018	0.000	0.000	0.034
CCISeismic fujitsu TA08025-B605	49.000	0.000	0.000	0.018	0.000	0.000	0.034
CCISeismic Commscope MC-PK8-DSH	49.000	0.000	0.000	0.432	0.000	0.000	0.825
CCISeismic (2) ubiquiti network AM-5G19-120 w/ Mount Pipe	39.000	0.000	0.000	0.012	0.000	0.000	0.016
CCISeismic (2) ubiquiti network AM-5G19-120 w/ Mount Pipe	39.000	0.000	0.000	0.012	0.000	0.000	0.016
CCISeismic (2) mikrotik NETMETAL AC2	39.000	0.000	0.000	0.001	0.000	0.000	0.001
CCISeismic (3) mikrotik NETMETAL AC2	39.000	0.000	0.000	0.001	0.000	0.000	0.002
CCISeismic (3) mikrotik NETMETAL AC2	39.000	0.000	0.000	0.001	0.000	0.000	0.002
CCISeismic (2) tower mounts 8' x 2" Mount Pipe	39.000	0.000	0.000	0.014	0.000	0.000	0.018
CCISeismic (2) tower mounts 8' x 2" Mount Pipe	39.000	0.000	0.000	0.014	0.000	0.000	0.018
CCISeismic (2) tower mounts 8' x 2" Mount Pipe	39.000	0.000	0.000	0.014	0.000	0.000	0.018
CCISeismic Site Pro 1 RMV12-396	39.000	0.000	0.000	0.186	0.000	0.000	0.247
CCISeismic kathrein 742 215 w/ Mount Pipe	19.000	0.000	0.000	0.008	0.000	0.000	0.003
CCISeismic kathrein 742 215 w/ Mount Pipe	19.000	0.000	0.000	0.008	0.000	0.000	0.003
CCISeismic tower mounts Side Arm Mount [SO 102-3]	19.000	0.000	0.000	0.018	0.000	0.000	0.008
CCISeismic matsing MS-MBA-3.2-H4-L4 w/ Mount Pipe	61.000	0.000	0.000	0.037	0.000	0.000	0.101
CCISeismic cambridge broadband networks group 39GHz VectaStar w/ Mount Pipe	61.000	0.000	0.000	0.012	0.000	0.000	0.032
CCISeismic commscope NHH-33B-R2B w/ Mount Pipe	61.000	0.000	0.000	0.032	0.000	0.000	0.087

Description	Elevation	Offset From Centroid	Azimuth Angle	E_v	E_{hx}	E_{hz}	E_h
	ft	ft	°	K	K	K	K
CCISeismic ericsson AIR 6449 B77D_CCIV3 w/ Mount Pipe	61.000	0.000	0.000	0.026	0.000	0.000	0.071
CCISeismic commscope NHH-33B-R2B w/ Mount Pipe	61.000	0.000	0.000	0.032	0.000	0.000	0.087
CCISeismic ericsson AIR 6449 B77D_CCIV3 w/ Mount Pipe	61.000	0.000	0.000	0.026	0.000	0.000	0.071
CCISeismic cambridge broadband networks group 39GHz VectaStar w/ Mount Pipe	61.000	0.000	0.000	0.012	0.000	0.000	0.032
CCISeismic ericsson AIR 6449 B77D_CCIV3 w/ Mount Pipe	61.000	0.000	0.000	0.026	0.000	0.000	0.071
CCISeismic matsing MS- MBA-3.2-H4-L4 w/ Mount Pipe	61.000	0.000	0.000	0.037	0.000	0.000	0.101
CCISeismic commscope NHH-33B-R2B w/ Mount Pipe	61.000	0.000	0.000	0.032	0.000	0.000	0.087
CCISeismic cambridge broadband networks group 39GHz VectaStar w/ Mount Pipe	61.000	0.000	0.000	0.012	0.000	0.000	0.032
CCISeismic commscope NHH-33B-R2B w/ Mount Pipe	61.000	0.000	0.000	0.032	0.000	0.000	0.087
CCISeismic cambridge broadband networks group 39GHz VectaStar w/ Mount Pipe	61.000	0.000	0.000	0.012	0.000	0.000	0.032
CCISeismic ericsson 4449	61.000	0.000	0.000	0.017	0.000	0.000	0.046
CCISeismic raycap RCMDC- 3315-PF-48	61.000	0.000	0.000	0.008	0.000	0.000	0.021
CCISeismic (6) commscope CBC1923T-DS-43	61.000	0.000	0.000	0.011	0.000	0.000	0.031
CCISeismic ericsson 8843	61.000	0.000	0.000	0.017	0.000	0.000	0.047
CCISeismic ericsson 8843	61.000	0.000	0.000	0.017	0.000	0.000	0.047
CCISeismic (2) ericsson 8843	61.000	0.000	0.000	0.035	0.000	0.000	0.093
CCISeismic raycap RCMDC- 3315-PF-48	61.000	0.000	0.000	0.008	0.000	0.000	0.021
CCISeismic ericsson 4449	61.000	0.000	0.000	0.017	0.000	0.000	0.046
CCISeismic commscope CBC1923T-DS-43	61.000	0.000	0.000	0.002	0.000	0.000	0.005
CCISeismic (2) ericsson 4449	61.000	0.000	0.000	0.034	0.000	0.000	0.092
CCISeismic (2) ericsson 8843	61.000	0.000	0.000	0.035	0.000	0.000	0.093
CCISeismic (5) commscope CBC1923T-DS-43	61.000	0.000	0.000	0.010	0.000	0.000	0.026
CCISeismic (2) ericsson 8843	61.000	0.000	0.000	0.035	0.000	0.000	0.093
CCISeismic ericsson 4449	61.000	0.000	0.000	0.017	0.000	0.000	0.046
CCISeismic ericsson 4449	61.000	0.000	0.000	0.017	0.000	0.000	0.046
CCISeismic (4) tower mounts T-Arm Mount [TA 601-1]	61.000	0.000	0.000	0.232	0.000	0.000	0.626
CCISeismic (2) tower mounts T-Arm Mount [TA 601-1]	61.000	0.000	0.000	0.116	0.000	0.000	0.313
CCISeismic (2) tower mounts T-Arm Mount [TA 601-1]	61.000	0.000	0.000	0.116	0.000	0.000	0.313
CCISeismic (2) tower mounts T-Arm Mount [TA 601-1]	61.000	0.000	0.000	0.012	0.000	0.000	0.032
CCISeismic (2) tower mounts 8'X2" Horizontal Pipe	61.000	0.000	0.000	0.006	0.000	0.000	0.016
CCISeismic tower mounts 8'X2" Horizontal Pipe	61.000	0.000	0.000	0.006	0.000	0.000	0.016
CCISeismic tower mounts 8'X2" Horizontal Pipe	61.000	0.000	0.000	0.006	0.000	0.000	0.016
CCISeismic tower mounts 2' x 2" Pipe Mount	61.000	0.000	0.000	0.002	0.000	0.000	0.004
CCISeismic (4) tower mounts 2' x 2" Pipe Mount	61.000	0.000	0.000	0.007	0.000	0.000	0.018
CCISeismic tower mounts 8' x 2" Mount Pipe	61.000	0.000	0.000	0.007	0.000	0.000	0.019

Description	Elevation	Offset From Centroid	Azimuth Angle	E_v	E_{hx}	E_{hz}	E_h
	ft	ft	°	K	K	K	K
CCISeismic tower mounts 8' x 2" Mount Pipe	61.000	0.000	0.000	0.007	0.000	0.000	0.019
CCISeismic ubiquiti network RD-5G30	39.000	0.000	0.000	0.005	0.000	0.000	0.007
CCISeismic ubiquiti network RD-5G30	39.000	0.000	0.000	0.005	0.000	0.000	0.007
CCISeismic ubiquiti network RD-5G30	39.000	0.000	0.000	0.005	0.000	0.000	0.007
CCISeismic ubiquiti network RD-5G30	39.000	0.000	0.000	0.005	0.000	0.000	0.007
CCISeismic (20) andrew LDF5-50A(7/8) From 0 to 61 (55.9ft to61ft)	58.450	0.000	0.000	0.008	0.000	0.000	0.020
CCISeismic (20) andrew LDF5-50A(7/8) From 0 to 61 (45.9ft to55.9ft)	50.900	0.000	0.000	0.016	0.000	0.000	0.032
CCISeismic (20) andrew LDF5-50A(7/8) From 0 to 61 (35.9ft to45.9ft)	40.900	0.000	0.000	0.016	0.000	0.000	0.023
CCISeismic (20) andrew LDF5-50A(7/8) From 0 to 61 (25.9ft to35.9ft)	30.900	0.000	0.000	0.016	0.000	0.000	0.015
CCISeismic (20) andrew LDF5-50A(7/8) From 0 to 61 (15.9ft to25.9ft)	20.900	0.000	0.000	0.016	0.000	0.000	0.008
CCISeismic (20) andrew LDF5-50A(7/8) From 0 to 61 (5.90000000000001ft to15.9ft)	10.900	0.000	0.000	0.016	0.000	0.000	0.003
CCISeismic (20) andrew LDF5-50A(7/8) From 0 to 61 (0ft to5.90000000000001ft)	2.950	0.000	0.000	0.009	0.000	0.000	0.000
CCISeismic (2) commscope RFA1608-16S26-XXX(1-1/4) From 0 to 61 (55.9ft to61ft)	58.450	0.000	0.000	0.003	0.000	0.000	0.008
CCISeismic (2) commscope RFA1608-16S26-XXX(1-1/4) From 0 to 61 (45.9ft to55.9ft)	50.900	0.000	0.000	0.006	0.000	0.000	0.013
CCISeismic (2) commscope RFA1608-16S26-XXX(1-1/4) From 0 to 61 (35.9ft to45.9ft)	40.900	0.000	0.000	0.006	0.000	0.000	0.009
CCISeismic (2) commscope RFA1608-16S26-XXX(1-1/4) From 0 to 61 (25.9ft to35.9ft)	30.900	0.000	0.000	0.006	0.000	0.000	0.006
CCISeismic (2) commscope RFA1608-16S26-XXX(1-1/4) From 0 to 61 (15.9ft to25.9ft)	20.900	0.000	0.000	0.006	0.000	0.000	0.003
CCISeismic (2) commscope RFA1608-16S26-XXX(1-1/4) From 0 to 61 (5.90000000000001ft to15.9ft)	10.900	0.000	0.000	0.006	0.000	0.000	0.001
CCISeismic (2) commscope RFA1608-16S26-XXX(1-1/4) From 0 to 61 (0ft to5.90000000000001ft)	2.950	0.000	0.000	0.004	0.000	0.000	0.000
CCISeismic (2) andrew LDF5-50A(7/8) From 0 to 56 (45.9ft to55.9ft)	50.900	0.000	0.000	0.002	0.000	0.000	0.003
CCISeismic (2) andrew LDF5-50A(7/8) From 0 to 56 (35.9ft to45.9ft)	40.900	0.000	0.000	0.002	0.000	0.000	0.002
CCISeismic (2) andrew LDF5-50A(7/8) From 0 to 56 (25.9ft to35.9ft)	30.900	0.000	0.000	0.002	0.000	0.000	0.002
CCISeismic (2) andrew LDF5-50A(7/8) From 0 to 56 (15.9ft to25.9ft)	20.900	0.000	0.000	0.002	0.000	0.000	0.001

Description	Elevation	Offset From Centroid	Azimuth Angle	E_v	E_{hx}	E_{hz}	E_h
	ft	ft	°	K	K	K	K
CCISeismic (2) andrew LDF5-50A(7/8) From 0 to 56 (5.90000000000001ft to15.9ft)	10.900	0.000	0.000	0.002	0.000	0.000	0.000
CCISeismic (2) andrew LDF5-50A(7/8) From 0 to 56 (0ft to5.90000000000001ft)	2.950	0.000	0.000	0.001	0.000	0.000	0.000
CCISeismic cui CU12PSM9P8XXX(1-3/8) From 0 to 49 (45.9ft to49ft)	47.450	0.000	0.000	0.001	0.000	0.000	0.002
CCISeismic cui CU12PSM9P8XXX(1-3/8) From 0 to 49 (35.9ft to45.9ft)	40.900	0.000	0.000	0.004	0.000	0.000	0.006
CCISeismic cui CU12PSM9P8XXX(1-3/8) From 0 to 49 (25.9ft to35.9ft)	30.900	0.000	0.000	0.004	0.000	0.000	0.004
CCISeismic cui CU12PSM9P8XXX(1-3/8) From 0 to 49 (15.9ft to25.9ft)	20.900	0.000	0.000	0.004	0.000	0.000	0.002
CCISeismic cui CU12PSM9P8XXX(1-3/8) From 0 to 49 (5.90000000000001ft to15.9ft)	10.900	0.000	0.000	0.004	0.000	0.000	0.001
CCISeismic cui CU12PSM9P8XXX(1-3/8) From 0 to 49 (0ft to5.90000000000001ft)	2.950	0.000	0.000	0.002	0.000	0.000	0.000
CCISeismic (8) alcatel lucent CAT5E(1/4) From 0 to 39 (35.9ft to39ft)	37.450	0.000	0.000	0.000	0.000	0.000	0.000
CCISeismic (8) alcatel lucent CAT5E(1/4) From 0 to 39 (25.9ft to35.9ft)	30.900	0.000	0.000	0.001	0.000	0.000	0.001
CCISeismic (8) alcatel lucent CAT5E(1/4) From 0 to 39 (15.9ft to25.9ft)	20.900	0.000	0.000	0.001	0.000	0.000	0.000
CCISeismic (8) alcatel lucent CAT5E(1/4) From 0 to 39 (5.90000000000001ft to15.9ft)	10.900	0.000	0.000	0.001	0.000	0.000	0.000
CCISeismic (8) alcatel lucent CAT5E(1/4) From 0 to 39 (0ft to5.90000000000001ft)	2.950	0.000	0.000	0.001	0.000	0.000	0.000
CCISeismic (9) andrew LDF4-50A(1/2) From 0 to 19 (15.9ft to19ft)	17.450	0.000	0.000	0.001	0.000	0.000	0.000
CCISeismic (9) andrew LDF4-50A(1/2) From 0 to 19 (5.90000000000001ft to15.9ft)	10.900	0.000	0.000	0.003	0.000	0.000	0.001
CCISeismic (9) andrew LDF4-50A(1/2) From 0 to 19 (0ft to5.90000000000001ft)	2.950	0.000	0.000	0.002	0.000	0.000	0.000
CCISeismic (4) andrew LDF5-50A(7/8) From 0 to 19 (15.9ft to19ft)	17.450	0.000	0.000	0.001	0.000	0.000	0.000
CCISeismic (4) andrew LDF5-50A(7/8) From 0 to 19 (5.90000000000001ft to15.9ft)	10.900	0.000	0.000	0.003	0.000	0.000	0.001
CCISeismic (4) andrew LDF5-50A(7/8) From 0 to 19 (0ft to5.90000000000001ft)	2.950	0.000	0.000	0.002	0.000	0.000	0.000
CCISeismic (4) andrew LDF4-50A(1/2) From 0 to 19 (15.9ft to19ft)	17.450	0.000	0.000	0.000	0.000	0.000	0.000
CCISeismic (4) andrew LDF4-50A(1/2) From 0 to 19 (5.90000000000001ft to15.9ft)	10.900	0.000	0.000	0.001	0.000	0.000	0.000

Description	Elevation	Offset From Centroid	Azimuth Angle	E_v	E_{hx}	E_{hz}	E_h
	ft	ft	°	K	K	K	K
50A(1/2) From 0 to 19 (5.90000000000001ft to 15.9ft)							
CCISeismic (4) andrew LDF4-50A(1/2) From 0 to 19 (0ft to 5.90000000000001ft)	2.950	0.000	0.000	0.001	0.000	0.000	0.000
CCISeismic misc Safety Line 5/8 From 0 to 65.5 (55.9ft to 65.5ft)	60.700	0.000	0.000	0.001	0.000	0.000	0.003
CCISeismic misc Safety Line 5/8 From 0 to 65.5 (45.9ft to 55.9ft)	50.900	0.000	0.000	0.001	0.000	0.000	0.002
CCISeismic misc Safety Line 5/8 From 0 to 65.5 (35.9ft to 45.9ft)	40.900	0.000	0.000	0.001	0.000	0.000	0.001
CCISeismic misc Safety Line 5/8 From 0 to 65.5 (25.9ft to 35.9ft)	30.900	0.000	0.000	0.001	0.000	0.000	0.001
CCISeismic misc Safety Line 5/8 From 0 to 65.5 (15.9ft to 25.9ft)	20.900	0.000	0.000	0.001	0.000	0.000	0.001
CCISeismic misc Safety Line 5/8 From 0 to 65.5 (5.90000000000001ft to 15.9ft)	10.900	0.000	0.000	0.001	0.000	0.000	0.000
CCISeismic misc Safety Line 5/8 From 0 to 65.5 (0ft to 5.90000000000001ft)	2.950	0.000	0.000	0.001	0.000	0.000	0.000

Discrete Tower Loads

Description	Face or Leg	Offset Type	Offsets: Horz Lateral Vert	Azimuth Adjustmen t	Placement	C_{AA} Front	C_{AA} Side	Weight	
			ft ft ft	°	ft	ft ²	ft ²	K	
*56/ 742 215 w/ Mount Pipe	A	From Leg	0.500 0.000 -1.000	0.000	56.000	No Ice	2.360	1.990	0.033
Side Arm Mount [SO 102-3]	A	None		0.000	56.000	No Ice	3.600	3.600	0.075
*48/ MX08FRO665-21	A	From Leg	4.000 0.000 0.000	0.000	49.000	No Ice	8.011	3.211	0.083
MX08FRO665-21	B	From Leg	4.000 0.000 0.000	0.000	49.000	No Ice	8.011	3.211	0.083
MX08FRO665-21	C	From Leg	4.000 0.000 0.000	0.000	49.000	No Ice	8.011	3.211	0.083
TA08025-B604	A	From Leg	4.000 0.000 0.000	0.000	49.000	No Ice	1.964	1.033	0.064
TA08025-B604	B	From Leg	4.000 0.000 0.000	0.000	49.000	No Ice	1.964	1.033	0.064
TA08025-B604	C	From Leg	4.000 0.000 0.000	0.000	49.000	No Ice	1.964	1.033	0.064
RDIDC-9181-PF-48	A	From Leg	4.000	0.000	49.000	No Ice	1.867	1.067	0.022

Description	Face or Leg	Offset Type	Offsets: Horz Lateral Vert ft ft ft	Azimuth Adjustment t °	Placement ft		C _A A _A Front ft ²	C _A A _A Side ft ²	Weight K
TA08025-B605	A	From Leg	0.000 0.000 4.000	0.000	49.000	No Ice	2.226	1.189	0.075
TA08025-B605	B	From Leg	0.000 0.000 4.000	0.000	49.000	No Ice	2.226	1.189	0.075
TA08025-B605	C	From Leg	0.000 0.000 4.000	0.000	49.000	No Ice	2.226	1.189	0.075
Commscope MC-PK8-DSH *39/	C	None	0.000	0.000	49.000	No Ice	34.230	33.140	1.802
(2) AM-5G19-120 w/ Mount Pipe	B	From Leg	4.000 0.000 0.000	0.000	39.000	No Ice	1.542	1.479	0.025
(2) AM-5G19-120 w/ Mount Pipe	C	From Leg	4.000 0.000 0.000	0.000	39.000	No Ice	1.542	1.479	0.025
(2) NETMETAL AC2	A	From Leg	4.000 0.000 0.000	0.000	39.000	No Ice	0.456	0.168	0.002
(3) NETMETAL AC2	B	From Leg	4.000 0.000 0.000	0.000	39.000	No Ice	0.456	0.168	0.002
(3) NETMETAL AC2	C	From Leg	4.000 0.000 0.000	0.000	39.000	No Ice	0.456	0.168	0.002
(2) 8' x 2" Mount Pipe	A	From Leg	4.000 0.000 0.000	0.000	39.000	No Ice	1.900	1.900	0.029
(2) 8' x 2" Mount Pipe	B	From Leg	4.000 0.000 0.000	0.000	39.000	No Ice	1.900	1.900	0.029
(2) 8' x 2" Mount Pipe	C	From Leg	4.000 0.000 0.000	0.000	39.000	No Ice	1.900	1.900	0.029
Site Pro 1 RMV12-396 *19/	C	None	0.000	0.000	39.000	No Ice	13.400	13.400	0.774
742 215 w/ Mount Pipe	B	From Leg	0.500 0.000 0.000	0.000	19.000	No Ice	2.360	1.990	0.033
742 215 w/ Mount Pipe	C	From Leg	0.500 0.000 1.000	0.000	19.000	No Ice	2.360	1.990	0.033
Side Arm Mount [SO 102- 3] *61/	C	None	0.000	0.000	19.000	No Ice	3.600	3.600	0.075
MS-MBA-3.2-H4-L4 w/ Mount Pipe	A	From Leg	4.000 0.000 2.000	40.000	61.000	No Ice	13.476	14.227	0.156
39GHz VectaStar w/ Mount Pipe	A	From Leg	4.000 0.000 2.000	-90.000	61.000	No Ice	2.586	1.802	0.049
NHH-33B-R2B w/ Mount Pipe	A	From Leg	4.000 0.000 2.000	-40.000	61.000	No Ice	9.765	4.848	0.134
AIR 6449 B77D_CCIV3 w/ Mount Pipe	A	From Leg	4.000 0.000 4.000	-25.000	61.000	No Ice	3.650	2.720	0.110
NHH-33B-R2B w/ Mount Pipe	B	From Leg	4.000 0.000 2.000	-15.000	61.000	No Ice	9.765	4.848	0.134
AIR 6449 B77D_CCIV3 w/ Mount Pipe	B	From Leg	4.000 0.000	-25.000	61.000	No Ice	3.650	2.720	0.110

Description	Face or Leg	Offset Type	Offsets: Horz Lateral Vert ft ft ft	Azimuth Adjustment t °	Placement ft		C _{AA} Front ft ²	C _{AA} Side ft ²	Weight K
39GHz VectaStar w/ Mount Pipe	B	From Leg	4.000 4.000 0.000	30.000	61.000	No Ice	2.586	1.802	0.049
AIR 6449 B77D_CCIV3 w/ Mount Pipe	B	From Leg	2.000 4.000 0.000	90.000	61.000	No Ice	3.650	2.720	0.110
MS-MBA-3.2-H4-L4 w/ Mount Pipe	C	From Leg	4.000 4.000 0.000	-25.000	61.000	No Ice	13.476	14.227	0.156
NHH-33B-R2B w/ Mount Pipe	C	From Leg	2.000 4.000 0.000	10.000	61.000	No Ice	9.765	4.848	0.134
39GHz VectaStar w/ Mount Pipe	C	From Leg	2.000 4.000 0.000	0.000	61.000	No Ice	2.586	1.802	0.049
NHH-33B-R2B w/ Mount Pipe	C	From Leg	2.000 4.000 0.000	50.000	61.000	No Ice	9.765	4.848	0.134
39GHz VectaStar w/ Mount Pipe	C	From Leg	2.000 4.000 0.000	90.000	61.000	No Ice	2.586	1.802	0.049
4449	A	From Leg	2.000 4.000 0.000	40.000	61.000	No Ice	1.969	1.402	0.071
RCMDC-3315-PF-48	A	From Leg	2.000 4.000 0.000	-90.000	61.000	No Ice	3.708	2.192	0.032
(6) CBC1923T-DS-43	A	From Leg	2.000 4.000 0.000	-90.000	61.000	No Ice	0.316	0.230	0.008
8843	A	From Leg	2.000 4.000 0.000	-90.000	61.000	No Ice	1.650	1.363	0.072
8843	A	From Leg	2.000 4.000 0.000	-40.000	61.000	No Ice	1.650	1.363	0.072
(2) 8843	B	From Leg	2.000 4.000 0.000	-15.000	61.000	No Ice	1.650	1.363	0.072
RCMDC-3315-PF-48	B	From Leg	2.000 4.000 0.000	-25.000	61.000	No Ice	3.708	2.192	0.032
4449	B	From Leg	2.000 4.000 0.000	-25.000	61.000	No Ice	1.969	1.402	0.071
CBC1923T-DS-43	C	From Leg	2.000 4.000 0.000	10.000	61.000	No Ice	0.316	0.230	0.008
(2) 4449	C	From Leg	2.000 4.000 0.000	10.000	61.000	No Ice	1.969	1.402	0.071
(2) 8843	C	From Leg	2.000 4.000 0.000	10.000	61.000	No Ice	1.650	1.363	0.072
(5) CBC1923T-DS-43	C	From Leg	2.000 4.000 0.000	0.000	61.000	No Ice	0.316	0.230	0.008
(2) 8843	C	From Leg	2.000 4.000 0.000	0.000	61.000	No Ice	1.650	1.363	0.072
4449	C	From Leg	2.000 4.000 0.000	50.000	61.000	No Ice	1.969	1.402	0.071
4449	C	From Leg	2.000 4.000	90.000	61.000	No Ice	1.969	1.402	0.071

Description	Face or Leg	Offset Type	Offsets: Horz Lateral Vert ft ft ft	Azimuth Adjustment t °	Placement ft		C _A A _A Front ft ²	C _A A _A Side ft ²	Weight K
(4) T-Arm Mount [TA 601-1]	A	From Leg	0.000 2.000 4.000	0.000	61.000	No Ice	7.970	2.500	0.242
(2) T-Arm Mount [TA 601-1]	B	From Leg	0.000 0.000 4.000	0.000	61.000	No Ice	7.970	2.500	0.242
(2) T-Arm Mount [TA 601-1]	C	From Leg	0.000 0.000 4.000	0.000	61.000	No Ice	7.970	2.500	0.242
(2) 8'X2" Horizontal Pipe	A	From Leg	0.000 0.000 4.000	0.000	61.000	No Ice	1.600	1.600	0.025
8'X2" Horizontal Pipe	B	From Leg	0.000 0.000 4.000	0.000	61.000	No Ice	1.600	1.600	0.025
8'X2" Horizontal Pipe	C	From Leg	0.000 0.000 4.000	0.000	61.000	No Ice	1.600	1.600	0.025
2' x 2" Pipe Mount	A	From Leg	0.000 0.000 4.000	0.000	61.000	No Ice	0.023	0.023	0.007
(4) 2' x 2" Pipe Mount	B	From Leg	0.000 0.000 4.000	0.000	61.000	No Ice	0.023	0.023	0.007
8' x 2" Mount Pipe	A	From Leg	0.000 0.000 2.000	0.000	61.000	No Ice	1.900	1.900	0.029
8' x 2" Mount Pipe	C	From Leg	0.000 0.000 2.000	0.000	61.000	No Ice	1.900	1.900	0.029

Dishes

Description	Face or Leg	Dish Type	Offset Type	Offsets: Horz Lateral Vert ft ft ft	Azimuth Adjustment °	3 dB Beam Width °	Elevation ft	Outside Diameter ft		Aperture Area ft ²	Weight K
RD-5G30	A	Paraboloid w/o Radome	From Leg	4.000 0.000 0.000	-5.000		39.000	2.133	No Ice	3.574	0.022
RD-5G30	A	Paraboloid w/o Radome	From Leg	4.000 0.000 0.000	90.000		39.000	2.133	No Ice	3.574	0.022
RD-5G30	B	Paraboloid w/o Radome	From Leg	4.000 0.000 0.000	90.000		39.000	2.133	No Ice	3.574	0.022
RD-5G30	C	Paraboloid w/o Radome	From Leg	4.000 0.000 0.000	0.000		39.000	2.133	No Ice	3.574	0.022

Load Combinations

Comb. No.	Description
1	Dead Only
2	1.2 Dead+1.0 Wind 0 deg - No Ice
3	0.9 Dead+1.0 Wind 0 deg - No Ice
4	1.2 Dead+1.0 Wind 30 deg - No Ice
5	0.9 Dead+1.0 Wind 30 deg - No Ice
6	1.2 Dead+1.0 Wind 60 deg - No Ice
7	0.9 Dead+1.0 Wind 60 deg - No Ice
8	1.2 Dead+1.0 Wind 90 deg - No Ice
9	0.9 Dead+1.0 Wind 90 deg - No Ice
10	1.2 Dead+1.0 Wind 120 deg - No Ice
11	0.9 Dead+1.0 Wind 120 deg - No Ice
12	1.2 Dead+1.0 Wind 150 deg - No Ice
13	0.9 Dead+1.0 Wind 150 deg - No Ice
14	1.2 Dead+1.0 Wind 180 deg - No Ice
15	0.9 Dead+1.0 Wind 180 deg - No Ice
16	1.2 Dead+1.0 Wind 210 deg - No Ice
17	0.9 Dead+1.0 Wind 210 deg - No Ice
18	1.2 Dead+1.0 Wind 240 deg - No Ice
19	0.9 Dead+1.0 Wind 240 deg - No Ice
20	1.2 Dead+1.0 Wind 270 deg - No Ice
21	0.9 Dead+1.0 Wind 270 deg - No Ice
22	1.2 Dead+1.0 Wind 300 deg - No Ice
23	0.9 Dead+1.0 Wind 300 deg - No Ice
24	1.2 Dead+1.0 Wind 330 deg - No Ice
25	0.9 Dead+1.0 Wind 330 deg - No Ice
26	Dead+Wind 0 deg - Service
27	Dead+Wind 30 deg - Service
28	Dead+Wind 60 deg - Service
29	Dead+Wind 90 deg - Service
30	Dead+Wind 120 deg - Service
31	Dead+Wind 150 deg - Service
32	Dead+Wind 180 deg - Service
33	Dead+Wind 210 deg - Service
34	Dead+Wind 240 deg - Service
35	Dead+Wind 270 deg - Service
36	Dead+Wind 300 deg - Service
37	Dead+Wind 330 deg - Service
38	1.2 Dead+1.0 Ev+1.0 Eh 0 deg
39	0.9 Dead-1.0 Ev+1.0 Eh 0 deg
40	1.2 Dead+1.0 Ev+1.0 Eh 30 deg
41	0.9 Dead-1.0 Ev+1.0 Eh 30 deg
42	1.2 Dead+1.0 Ev+1.0 Eh 60 deg
43	0.9 Dead-1.0 Ev+1.0 Eh 60 deg
44	1.2 Dead+1.0 Ev+1.0 Eh 90 deg
45	0.9 Dead-1.0 Ev+1.0 Eh 90 deg
46	1.2 Dead+1.0 Ev+1.0 Eh 120 deg
47	0.9 Dead-1.0 Ev+1.0 Eh 120 deg
48	1.2 Dead+1.0 Ev+1.0 Eh 150 deg
49	0.9 Dead-1.0 Ev+1.0 Eh 150 deg
50	1.2 Dead+1.0 Ev+1.0 Eh 180 deg
51	0.9 Dead-1.0 Ev+1.0 Eh 180 deg
52	1.2 Dead+1.0 Ev+1.0 Eh 210 deg
53	0.9 Dead-1.0 Ev+1.0 Eh 210 deg
54	1.2 Dead+1.0 Ev+1.0 Eh 240 deg
55	0.9 Dead-1.0 Ev+1.0 Eh 240 deg
56	1.2 Dead+1.0 Ev+1.0 Eh 270 deg
57	0.9 Dead-1.0 Ev+1.0 Eh 270 deg
58	1.2 Dead+1.0 Ev+1.0 Eh 300 deg
59	0.9 Dead-1.0 Ev+1.0 Eh 300 deg
60	1.2 Dead+1.0 Ev+1.0 Eh 330 deg
61	0.9 Dead-1.0 Ev+1.0 Eh 330 deg

Maximum Member Forces

Section No.	Elevation ft	Component Type	Condition	Gov. Load Comb.	Axial K	Major Axis Moment kip-ft	Minor Axis Moment kip-ft
L1	65.9 - 31.7	Pole	Max Tension	38	0.000	-0.000	-0.000
			Max. Compression	46	-15.169	-100.716	-57.495
			Max. Mx	20	-12.405	212.204	6.074
			Max. My	2	-12.417	5.495	204.939
			Max. Vy	8	10.491	-207.431	-1.117
			Max. Vx	2	-10.265	5.495	204.939
L2	31.7 - 0	Pole	Max. Torque	16			-3.285
			Max Tension	1	0.000	0.000	0.000
			Max. Compression	46	-21.120	-282.973	-162.951
			Max. Mx	20	-17.595	615.761	10.660
			Max. My	2	-17.595	2.602	601.615
			Max. Vy	8	12.757	-612.380	0.356
			Max. Vx	2	-12.525	2.602	601.615
			Max. Torque	16			-3.285

Maximum Reactions

Location	Condition	Gov. Load Comb.	Vertical K	Horizontal, X K	Horizontal, Z K
Pole	Max. Vert	58	21.122	5.216	3.012
	Max. H _x	20	17.603	12.703	0.134
	Max. H _z	2	17.603	-0.085	12.513
	Max. M _x	2	601.615	-0.085	12.513
	Max. M _z	8	612.380	-12.745	0.049
	Max. Torsion	4	2.317	-6.363	10.772
	Min. Vert	47	9.684	-5.216	-3.011
	Min. H _x	8	17.603	-12.745	0.049
	Min. H _z	14	17.603	-0.134	-12.477
	Min. M _x	14	-596.440	-0.134	-12.477
	Min. M _z	20	-615.761	12.703	0.134
	Min. Torsion	16	-3.236	6.315	-10.792

Tower Mast Reaction Summary

Load Combination	Vertical K	Shear _x K	Shear _z K	Overturning Moment, M _x kip-ft	Overturning Moment, M _z kip-ft	Torque kip-ft
Dead Only	14.669	0.000	0.000	-1.540	2.072	0.000
1.2 Dead+1.0 Wind 0 deg - No Ice	17.603	0.085	-12.513	-601.615	2.602	-2.044
0.9 Dead+1.0 Wind 0 deg - No Ice	13.203	0.085	-12.513	-597.659	1.937	-2.025
1.2 Dead+1.0 Wind 30 deg - No Ice	17.603	6.363	-10.772	-516.969	-301.582	-2.317
0.9 Dead+1.0 Wind 30 deg - No Ice	13.203	6.363	-10.772	-513.507	-300.473	-2.291
1.2 Dead+1.0 Wind 60 deg - No Ice	17.603	10.963	-6.260	-298.896	-525.352	-1.767
0.9 Dead+1.0 Wind 60 deg - No Ice	13.203	10.963	-6.260	-296.704	-522.935	-1.742
1.2 Dead+1.0 Wind 90 deg - No Ice	17.603	12.745	-0.049	-0.356	-612.380	-0.628
0.9 Dead+1.0 Wind 90 deg - No Ice	13.203	12.745	-0.049	0.103	-609.455	-0.610
1.2 Dead+1.0 Wind 120 deg - No Ice	17.603	11.066	6.349	304.656	-532.891	0.354
0.9 Dead+1.0 Wind 120 deg - No Ice	13.203	11.066	6.349	303.357	-530.422	0.359
1.2 Dead+1.0 Wind 150 deg - No Ice	17.603	6.384	10.876	520.819	-308.379	1.748

Load Combination	Vertical K	Shear _x K	Shear _z K	Overturning Moment, M _x kip-ft	Overturning Moment, M _z kip-ft	Torque kip-ft
0.9 Dead+1.0 Wind 150 deg - No Ice	13.203	6.384	10.876	518.271	-307.209	1.740
1.2 Dead+1.0 Wind 180 deg - No Ice	17.603	0.134	12.477	596.440	-6.257	2.548
0.9 Dead+1.0 Wind 180 deg - No Ice	13.203	0.134	12.477	593.456	-6.847	2.529
1.2 Dead+1.0 Wind 210 deg - No Ice	17.603	-6.315	10.792	514.030	304.710	3.236
0.9 Dead+1.0 Wind 210 deg - No Ice	13.203	-6.315	10.792	511.530	302.315	3.209
1.2 Dead+1.0 Wind 240 deg - No Ice	17.603	-10.979	6.205	292.968	531.010	2.494
0.9 Dead+1.0 Wind 240 deg - No Ice	13.203	-10.979	6.205	291.752	527.294	2.468
1.2 Dead+1.0 Wind 270 deg - No Ice	17.603	-12.703	-0.134	-10.660	615.761	1.221
0.9 Dead+1.0 Wind 270 deg - No Ice	13.203	-12.703	-0.134	-10.119	611.547	1.203
1.2 Dead+1.0 Wind 300 deg - No Ice	17.603	-11.073	-6.256	-304.713	538.175	-0.021
0.9 Dead+1.0 Wind 300 deg - No Ice	13.203	-11.073	-6.256	-302.465	534.409	-0.027
1.2 Dead+1.0 Wind 330 deg - No Ice	17.603	-6.463	-10.869	-524.294	316.556	-0.320
0.9 Dead+1.0 Wind 330 deg - No Ice	13.203	-6.463	-10.869	-520.781	314.075	-0.312
Dead+Wind 0 deg - Service	14.669	0.034	-5.012	-240.913	2.114	-0.813
Dead+Wind 30 deg - Service	14.669	2.549	-4.315	-207.131	-119.286	-0.925
Dead+Wind 60 deg - Service	14.669	4.392	-2.508	-120.098	-208.593	-0.706
Dead+Wind 90 deg - Service	14.669	5.105	-0.020	-0.948	-243.328	-0.249
Dead+Wind 120 deg - Service	14.669	4.433	2.543	120.790	-211.602	0.146
Dead+Wind 150 deg - Service	14.669	2.557	4.357	207.064	-121.994	0.703
Dead+Wind 180 deg - Service	14.669	0.054	4.998	237.243	-1.415	1.018
Dead+Wind 210 deg - Service	14.669	-2.530	4.323	204.354	122.694	1.288
Dead+Wind 240 deg - Service	14.669	-4.398	2.486	116.127	213.011	0.989
Dead+Wind 270 deg - Service	14.669	-5.089	-0.054	-5.055	246.835	0.484
Dead+Wind 300 deg - Service	14.669	-4.436	-2.506	-122.415	215.870	-0.008
Dead+Wind 330 deg - Service	14.669	-2.589	-4.354	-210.054	127.418	-0.122
1.2 Dead+1.0 Ev+1.0 Eh 0 deg	21.122	-0.000	-6.023	-331.567	2.538	-0.046
0.9 Dead-1.0 Ev+1.0 Eh 0 deg	9.684	0.000	-6.023	-325.967	1.854	-0.034
1.2 Dead+1.0 Ev+1.0 Eh 30 deg	21.122	3.012	-5.216	-287.399	-162.301	-0.061
0.9 Dead-1.0 Ev+1.0 Eh 30 deg	9.684	3.011	-5.216	-282.480	-160.442	-0.045
1.2 Dead+1.0 Ev+1.0 Eh 60 deg	21.122	5.216	-3.012	-166.728	-282.972	-0.059
0.9 Dead-1.0 Ev+1.0 Eh 60 deg	9.684	5.216	-3.011	-163.672	-279.251	-0.043
1.2 Dead+1.0 Ev+1.0 Eh 90 deg	21.122	6.023	0.000	-1.889	-327.141	-0.041
0.9 Dead-1.0 Ev+1.0 Eh 90 deg	9.684	6.023	0.000	-1.376	-322.738	-0.030
1.2 Dead+1.0 Ev+1.0 Eh 120 deg	21.122	5.216	3.012	162.951	-282.973	-0.012
0.9 Dead-1.0 Ev+1.0 Eh 120 deg	9.684	5.216	3.011	160.920	-279.251	-0.009
1.2 Dead+1.0 Ev+1.0 Eh 150 deg	21.122	3.012	5.216	283.622	-162.301	0.020
0.9 Dead-1.0 Ev+1.0 Eh 150 deg	9.684	3.011	5.216	279.729	-160.442	0.014

Load Combination	Vertical K	Shear _x K	Shear _z K	Overturning Moment, M _x kip-ft	Overturning Moment, M _z kip-ft	Torque kip-ft
deg						
1.2 Dead+1.0 Ev+1.0 Eh 180	21.122	-0.000	6.023	327.790	2.538	0.046
deg						
0.9 Dead-1.0 Ev+1.0 Eh 180	9.684	0.000	6.023	323.215	1.854	0.034
deg						
1.2 Dead+1.0 Ev+1.0 Eh 210	21.122	-3.012	5.216	283.621	167.377	0.061
deg						
0.9 Dead-1.0 Ev+1.0 Eh 210	9.684	-3.011	5.216	279.728	164.149	0.045
deg						
1.2 Dead+1.0 Ev+1.0 Eh 240	21.122	-5.216	3.012	162.950	288.048	0.059
deg						
0.9 Dead-1.0 Ev+1.0 Eh 240	9.684	-5.216	3.011	160.919	282.958	0.043
deg						
1.2 Dead+1.0 Ev+1.0 Eh 270	21.122	-6.023	0.000	-1.889	332.216	0.041
deg						
0.9 Dead-1.0 Ev+1.0 Eh 270	9.684	-6.023	0.000	-1.376	326.444	0.030
deg						
1.2 Dead+1.0 Ev+1.0 Eh 300	21.122	-5.216	-3.012	-166.728	288.047	0.013
deg						
0.9 Dead-1.0 Ev+1.0 Eh 300	9.684	-5.216	-3.011	-163.671	282.957	0.009
deg						
1.2 Dead+1.0 Ev+1.0 Eh 330	21.122	-3.012	-5.216	-287.398	167.377	-0.019
deg						
0.9 Dead-1.0 Ev+1.0 Eh 330	9.684	-3.011	-5.216	-282.480	164.149	-0.014
deg						

Solution Summary

Load Comb.	Sum of Applied Forces			Sum of Reactions			% Error
	PX K	PY K	PZ K	PX K	PY K	PZ K	
1	0.000	-14.669	0.000	0.000	14.669	0.000	0.000%
2	0.085	-17.603	-12.513	-0.085	17.603	12.513	0.000%
3	0.085	-13.203	-12.513	-0.085	13.203	12.513	0.000%
4	6.363	-17.603	-10.772	-6.363	17.603	10.772	0.000%
5	6.363	-13.203	-10.772	-6.363	13.203	10.772	0.000%
6	10.963	-17.603	-6.260	-10.963	17.603	6.260	0.000%
7	10.963	-13.203	-6.260	-10.963	13.203	6.260	0.000%
8	12.745	-17.603	-0.049	-12.745	17.603	0.049	0.000%
9	12.745	-13.203	-0.049	-12.745	13.203	0.049	0.000%
10	11.066	-17.603	6.349	-11.066	17.603	-6.349	0.000%
11	11.066	-13.203	6.349	-11.066	13.203	-6.349	0.000%
12	6.384	-17.603	10.876	-6.384	17.603	-10.876	0.000%
13	6.384	-13.203	10.876	-6.384	13.203	-10.876	0.000%
14	0.134	-17.603	12.477	-0.134	17.603	-12.477	0.000%
15	0.134	-13.203	12.477	-0.134	13.203	-12.477	0.000%
16	-6.315	-17.603	10.792	6.315	17.603	-10.792	0.000%
17	-6.315	-13.203	10.792	6.315	13.203	-10.792	0.000%
18	-10.979	-17.603	6.205	10.979	17.603	-6.205	0.000%
19	-10.979	-13.203	6.205	10.979	13.203	-6.205	0.000%
20	-12.703	-17.603	-0.134	12.703	17.603	0.134	0.000%
21	-12.703	-13.203	-0.134	12.703	13.203	0.134	0.000%
22	-11.073	-17.603	-6.256	11.073	17.603	6.256	0.000%
23	-11.073	-13.203	-6.256	11.073	13.203	6.256	0.000%
24	-6.463	-17.603	-10.869	6.463	17.603	10.869	0.000%
25	-6.463	-13.203	-10.869	6.463	13.203	10.869	0.000%
26	0.034	-14.669	-5.012	-0.034	14.669	5.012	0.000%
27	2.549	-14.669	-4.315	-2.549	14.669	4.315	0.000%
28	4.392	-14.669	-2.508	-4.392	14.669	2.508	0.000%
29	5.105	-14.669	-0.020	-5.105	14.669	0.020	0.000%
30	4.433	-14.669	2.543	-4.433	14.669	-2.543	0.000%
31	2.557	-14.669	4.357	-2.557	14.669	-4.357	0.000%
32	0.054	-14.669	4.998	-0.054	14.669	-4.998	0.000%
33	-2.530	-14.669	4.323	2.530	14.669	-4.323	0.000%
34	-4.398	-14.669	2.486	4.398	14.669	-2.486	0.000%
35	-5.089	-14.669	-0.054	5.089	14.669	0.054	0.000%

Load Comb.	Sum of Applied Forces			Sum of Reactions			% Error
	PX K	PY K	PZ K	PX K	PY K	PZ K	
36	-4.436	-14.669	-2.506	4.436	14.669	2.506	0.000%
37	-2.589	-14.669	-4.354	2.589	14.669	4.354	0.000%
38	0.000	-21.122	-6.023	0.000	21.122	6.023	0.000%
39	0.000	-9.684	-6.023	0.000	9.684	6.023	0.000%
40	3.011	-21.122	-5.216	-3.012	21.122	5.216	0.000%
41	3.011	-9.684	-5.216	-3.011	9.684	5.216	0.000%
42	5.216	-21.122	-3.011	-5.216	21.122	3.012	0.000%
43	5.216	-9.684	-3.011	-5.216	9.684	3.011	0.000%
44	6.023	-21.122	0.000	-6.023	21.122	0.000	0.000%
45	6.023	-9.684	0.000	-6.023	9.684	0.000	0.000%
46	5.216	-21.122	3.011	-5.216	21.122	-3.012	0.000%
47	5.216	-9.684	3.011	-5.216	9.684	-3.011	0.000%
48	3.011	-21.122	5.216	-3.012	21.122	-5.216	0.000%
49	3.011	-9.684	5.216	-3.011	9.684	-5.216	0.000%
50	0.000	-21.122	6.023	0.000	21.122	-6.023	0.000%
51	0.000	-9.684	6.023	0.000	9.684	-6.023	0.000%
52	-3.011	-21.122	5.216	3.012	21.122	-5.216	0.000%
53	-3.011	-9.684	5.216	3.011	9.684	-5.216	0.000%
54	-5.216	-21.122	3.011	5.216	21.122	-3.012	0.000%
55	-5.216	-9.684	3.011	5.216	9.684	-3.011	0.000%
56	-6.023	-21.122	0.000	6.023	21.122	0.000	0.000%
57	-6.023	-9.684	0.000	6.023	9.684	0.000	0.000%
58	-5.216	-21.122	-3.011	5.216	21.122	3.012	0.000%
59	-5.216	-9.684	-3.011	5.216	9.684	3.011	0.000%
60	-3.011	-21.122	-5.216	3.012	21.122	5.216	0.000%
61	-3.011	-9.684	-5.216	3.011	9.684	5.216	0.000%

Non-Linear Convergence Results

Load Combination	Converged?	Number of Cycles	Displacement Tolerance	Force Tolerance
1	Yes	4	0.00000001	0.00000001
2	Yes	4	0.00000001	0.00043217
3	Yes	4	0.00000001	0.00028218
4	Yes	4	0.00000001	0.00047331
5	Yes	4	0.00000001	0.00031109
6	Yes	4	0.00000001	0.00072685
7	Yes	4	0.00000001	0.00047462
8	Yes	4	0.00000001	0.00014885
9	Yes	4	0.00000001	0.00009528
10	Yes	4	0.00000001	0.00053307
11	Yes	4	0.00000001	0.00034749
12	Yes	4	0.00000001	0.00044579
13	Yes	4	0.00000001	0.00029157
14	Yes	4	0.00000001	0.00045888
15	Yes	4	0.00000001	0.00030136
16	Yes	4	0.00000001	0.00088821
17	Yes	4	0.00000001	0.00058368
18	Yes	4	0.00000001	0.00044547
19	Yes	4	0.00000001	0.00029163
20	Yes	4	0.00000001	0.00024501
21	Yes	4	0.00000001	0.00015800
22	Yes	4	0.00000001	0.00051329
23	Yes	4	0.00000001	0.00032727
24	Yes	4	0.00000001	0.00061821
25	Yes	4	0.00000001	0.00039758
26	Yes	4	0.00000001	0.00006923
27	Yes	4	0.00000001	0.00006507
28	Yes	4	0.00000001	0.00007799
29	Yes	4	0.00000001	0.00002458
30	Yes	4	0.00000001	0.00004007
31	Yes	4	0.00000001	0.00004780
32	Yes	4	0.00000001	0.00007468
33	Yes	4	0.00000001	0.00010711
34	Yes	4	0.00000001	0.00006112

35	Yes	4	0.00000001	0.00003792
36	Yes	4	0.00000001	0.00003661
37	Yes	4	0.00000001	0.00005523
38	Yes	4	0.00000001	0.00001751
39	Yes	4	0.00000001	0.00000001
40	Yes	4	0.00000001	0.00012726
41	Yes	4	0.00000001	0.00004683
42	Yes	4	0.00000001	0.00013545
43	Yes	4	0.00000001	0.00004924
44	Yes	4	0.00000001	0.00001613
45	Yes	4	0.00000001	0.00000001
46	Yes	4	0.00000001	0.00012359
47	Yes	4	0.00000001	0.00004582
48	Yes	4	0.00000001	0.00012296
49	Yes	4	0.00000001	0.00004564
50	Yes	4	0.00000001	0.00001700
51	Yes	4	0.00000001	0.00000001
52	Yes	4	0.00000001	0.00013712
53	Yes	4	0.00000001	0.00004971
54	Yes	4	0.00000001	0.00012891
55	Yes	4	0.00000001	0.00004730
56	Yes	4	0.00000001	0.00001670
57	Yes	4	0.00000001	0.00000001
58	Yes	4	0.00000001	0.00014147
59	Yes	4	0.00000001	0.00005087
60	Yes	4	0.00000001	0.00014210
61	Yes	4	0.00000001	0.00005105

Maximum Tower Deflections - Service Wind

Section No.	Elevation ft	Horz. Deflection in	Gov. Load Comb.	Tilt °	Twist °
L1	65.9 - 31.7	7.179	36	0.834	0.016
L2	34.886 - 0	2.295	36	0.580	0.006

Critical Deflections and Radius of Curvature - Service Wind

Elevation ft	Appurtenance	Gov. Load Comb.	Deflection in	Tilt °	Twist °	Radius of Curvature ft
63.800	CCISeismic Tower Section 1 - 1	36	6.803	0.821	0.015	17836
61.000	MS-MBA-3.2-H4-L4 w/ Mount Pipe	36	6.304	0.803	0.014	17836
60.700	CCISeismic misc Safety Line 5/8 From 0 to 65.5 (55.9ft to65.5ft)	36	6.251	0.801	0.014	17150
58.450	CCISeismic (20) andrew LDF5-50A(7/8) From 0 to 61 (55.9ft to61ft)	36	5.854	0.787	0.013	11970
56.700	CCISeismic Tower Section 1 - 2	36	5.549	0.775	0.013	9693
56.000	742 215 w/ Mount Pipe	36	5.428	0.770	0.013	9008
55.950	CCISeismic (2) andrew LDF5-50A(7/8) From 0 to 56 (55.9ft to56ft)	36	5.419	0.770	0.013	8963
50.900	CCISeismic (20) andrew LDF5-50A(7/8) From 0 to 61 (45.9ft to55.9ft)	36	4.569	0.734	0.011	5945
49.000	MX08FRO665-21	36	4.261	0.719	0.010	5277
47.450	CCISeismic cui CU12PSM9P8XXX(1-3/8) From 0 to 49 (45.9ft to49ft)	36	4.016	0.706	0.010	4833
46.700	CCISeismic Tower Section 1 - 3	36	3.900	0.700	0.009	4644
40.900	CCISeismic (20) andrew LDF5-50A(7/8) From 0 to 61 (35.9ft)	36	3.053	0.647	0.008	3567

Elevation ft	Appurtenance	Gov. Load Comb.	Deflection in	Tilt °	Twist °	Radius of Curvature ft
39.000	to45.9ft) RD-5G30	36	2.799	0.627	0.007	3316
37.450	CCISeismic (8) alcatel lucent CAT5E(1/4) From 0 to 39 (35.9ft to39ft)	36	2.601	0.610	0.007	3154
36.700	CCISeismic Tower Section 1 - 4	36	2.509	0.601	0.007	3097
32.443	CCISeismic Tower Section 2 - 1	36	2.028	0.549	0.005	3114
30.900	CCISeismic (20) andrew LDF5- 50A(7/8) From 0 to 61 (25.9ft to35.9ft)	36	1.871	0.529	0.005	3247
25.000	CCISeismic Tower Section 2 - 2	36	1.349	0.443	0.004	4012
20.900	CCISeismic (20) andrew LDF5- 50A(7/8) From 0 to 61 (15.9ft to25.9ft)	36	1.050	0.377	0.003	4798
19.000	742 215 w/ Mount Pipe	36	0.925	0.346	0.003	5278
17.450	CCISeismic (9) andrew LDF4- 50A(1/2) From 0 to 19 (15.9ft to19ft)	36	0.830	0.319	0.002	5747
15.000	CCISeismic Tower Section 2 - 3	36	0.690	0.277	0.002	6686
10.900	CCISeismic (20) andrew LDF5- 50A(7/8) From 0 to 61 (5.90000000000001ft to15.9ft)	36	0.478	0.203	0.001	9200
5.000	CCISeismic Tower Section 2 - 4	36	0.210	0.094	0.001	20057
2.950	CCISeismic (20) andrew LDF5- 50A(7/8) From 0 to 61 (0ft to5.90000000000001ft)	36	0.123	0.056	0.000	20057

Maximum Tower Deflections - Design Wind

Section No.	Elevation ft	Horz. Deflection in	Gov. Load Comb.	Tilt °	Twist °
L1	65.9 - 31.7	17.797	22	2.055	0.041
L2	34.886 - 0	5.712	22	1.442	0.015

Critical Deflections and Radius of Curvature - Design Wind

Elevation ft	Appurtenance	Gov. Load Comb.	Deflection in	Tilt °	Twist °	Radius of Curvature ft
63.800	CCISeismic Tower Section 1 - 1	22	16.868	2.024	0.039	7251
61.000	MS-MBA-3.2-H4-L4 w/ Mount Pipe	22	15.634	1.983	0.036	7251
60.700	CCISeismic miscel Safety Line 5/8 From 0 to 65.5 (55.9ft to65.5ft)	22	15.502	1.978	0.036	6972
58.450	CCISeismic (20) andrew LDF5- 50A(7/8) From 0 to 61 (55.9ft to61ft)	22	14.521	1.944	0.034	4866
56.700	CCISeismic Tower Section 1 - 2	22	13.766	1.916	0.032	3940
56.000	742 215 w/ Mount Pipe	22	13.466	1.905	0.032	3661
55.950	CCISeismic (2) andrew LDF5- 50A(7/8) From 0 to 56 (55.9ft to56ft)	22	13.445	1.904	0.032	3643
50.900	CCISeismic (20) andrew LDF5- 50A(7/8) From 0 to 61 (45.9ft to55.9ft)	22	11.341	1.817	0.027	2416
49.000	MX08FRO665-21	22	10.580	1.781	0.026	2144
47.450	CCISeismic cui CU12PSM9P8XXX(1-3/8) From 0 to 49 (45.9ft to49ft)	22	9.974	1.751	0.024	1964
46.700	CCISeismic Tower Section 1 - 3	22	9.686	1.736	0.024	1887

Elevation ft	Appurtenance	Gov. Load Comb.	Deflection in	Tilt °	Twist °	Radius of Curvature ft
40.900	CCISeismic (20) andrew LDF5-50A(7/8) From 0 to 61 (35.9ft to45.9ft)	22	7.590	1.605	0.019	1449
39.000	RD-5G30	22	6.960	1.557	0.018	1347
37.450	CCISeismic (8) alcatel lucent CAT5E(1/4) From 0 to 39 (35.9ft to39ft)	22	6.471	1.516	0.017	1281
36.700	CCISeismic Tower Section 1 - 4	22	6.242	1.495	0.016	1258
32.443	CCISeismic Tower Section 2 - 1	22	5.049	1.366	0.014	1265
30.900	CCISeismic (20) andrew LDF5-50A(7/8) From 0 to 61 (25.9ft to35.9ft)	22	4.661	1.315	0.013	1319
25.000	CCISeismic Tower Section 2 - 2	22	3.366	1.103	0.010	1629
20.900	CCISeismic (20) andrew LDF5-50A(7/8) From 0 to 61 (15.9ft to25.9ft)	22	2.620	0.940	0.008	1948
19.000	742 215 w/ Mount Pipe	22	2.311	0.862	0.007	2143
17.450	CCISeismic (9) andrew LDF4-50A(1/2) From 0 to 19 (15.9ft to19ft)	22	2.074	0.796	0.006	2333
15.000	CCISeismic Tower Section 2 - 3	22	1.725	0.690	0.005	2714
10.900	CCISeismic (20) andrew LDF5-50A(7/8) From 0 to 61 (5.90000000000001ft to15.9ft)	22	1.196	0.507	0.004	3734
5.000	CCISeismic Tower Section 2 - 4	10	0.526	0.235	0.002	8141
2.950	CCISeismic (20) andrew LDF5-50A(7/8) From 0 to 61 (0ft to5.90000000000001ft)	10	0.308	0.139	0.001	8141

Compression Checks

Pole Design Data

Section No.	Elevation ft	Size	L ft	L_u ft	Kl/r	A in^2	P_u K	ϕP_n K	Ratio $\frac{P_u}{\phi P_n}$
L1	65.9 - 31.7 (1)	TP25.487x19x0.25	34.200	0.000	0.0	19.829	-12.403	1160.010	0.011
L2	31.7 - 0 (2)	TP31x24.383x0.313	34.886	0.000	0.0	30.879	-17.595	1806.440	0.010

Pole Bending Design Data

Section No.	Elevation ft	Size	M_{ux} kip-ft	ϕM_{nx} kip-ft	Ratio $\frac{M_{ux}}{\phi M_{nx}}$	M_{uy} kip-ft	ϕM_{ny} kip-ft	Ratio $\frac{M_{uy}}{\phi M_{ny}}$
L1	65.9 - 31.7 (1)	TP25.487x19x0.25	214.422	688.835	0.311	0.000	688.835	0.000
L2	31.7 - 0 (2)	TP31x24.383x0.313	618.452	1337.992	0.462	0.000	1337.992	0.000

Pole Shear Design Data

Section No.	Elevation ft	Size	Actual V_u K	ϕV_n K	Ratio $\frac{V_u}{\phi V_n}$	Actual T_u kip-ft	ϕT_n kip-ft	Ratio $\frac{T_u}{\phi T_n}$
L1	65.9 - 31.7 (1)	TP25.487x19x0.25	10.473	348.004	0.030	0.061	754.043	0.000
L2	31.7 - 0 (2)	TP31x24.383x0.313	12.730	541.932	0.023	0.021	1462.867	0.000

Section No.	Elevation ft	Size	Actual V_u K	ϕV_n K	Ratio $\frac{V_u}{\phi V_n}$	Actual T_u kip-ft	ϕT_n kip-ft	Ratio $\frac{T_u}{\phi T_n}$
-------------	-----------------	------	-------------------	-----------------	------------------------------	------------------------	----------------------	------------------------------

Pole Interaction Design Data

Section No.	Elevation ft	Ratio P_u ϕP_n	Ratio M_{ux} ϕM_{nx}	Ratio M_{uy} ϕM_{ny}	Ratio V_u ϕV_n	Ratio T_u ϕT_n	Comb. Stress Ratio	Allow. Stress Ratio	Criteria
L1	65.9 - 31.7 (1)	0.011	0.311	0.000	0.030	0.000	0.323	1.050	
L2	31.7 - 0 (2)	0.010	0.462	0.000	0.023	0.000	0.473	1.050	

Section Capacity Table

Section No.	Elevation ft	Component Type	Size	Critical Element	P K	ϕP_{allow} K	% Capacity	Pass Fail	
L1	65.9 - 31.7	Pole	TP25.487x19x0.25	1	-12.403	1218.011	30.8	Pass	
L2	31.7 - 0	Pole	TP31x24.383x0.313	2	-17.595	1896.762	45.0	Pass	
							Summary		
							Pole (L2)	45.0	Pass
							RATING =	45.0	Pass

APPENDIX B
BASE LEVEL DRAWING

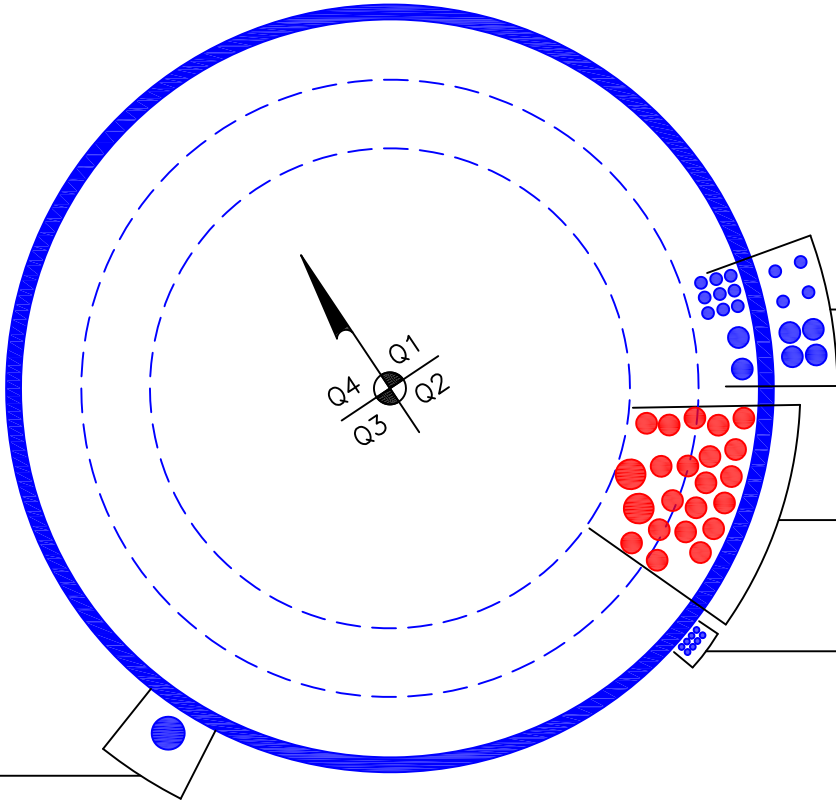

(OTHER CONSIDERED EQUIPMENTS)
(13) 1/2" TO 19 FT LEVEL
(4) 7/8" TO 19 FT LEVEL
(2) 7/8" TO 56 FT LEVEL

(PROPOSED EQUIPMENT CONFIGURATION)
(20) 7/8" TO 61 FT LEVEL
(2) 1-1/4" TO 61 FT LEVEL

(OTHER CONSIDERED EQUIPMENTS)
(8) 1/4" TO 39 FT LEVEL

(OTHER CONSIDERED EQUIPMENTS)
(1) 1-3/8" TO 49 FT LEVEL

APPENDIX C
ADDITIONAL CALCULATIONS

Monopole Base Plate Connection



Site Info	
BU #	815558
Site Name	NOVATO
Order #	690637 Rev. 0

Analysis Considerations	
TIA-222 Revision	H
Grout Considered:	No
l_{ar} (in)	0.25

Applied Loads	
Moment (kip-ft)	618.45
Axial Force (kips)	17.59
Shear Force (kips)	12.73

*TIA-222-H Section 15.5 Applied

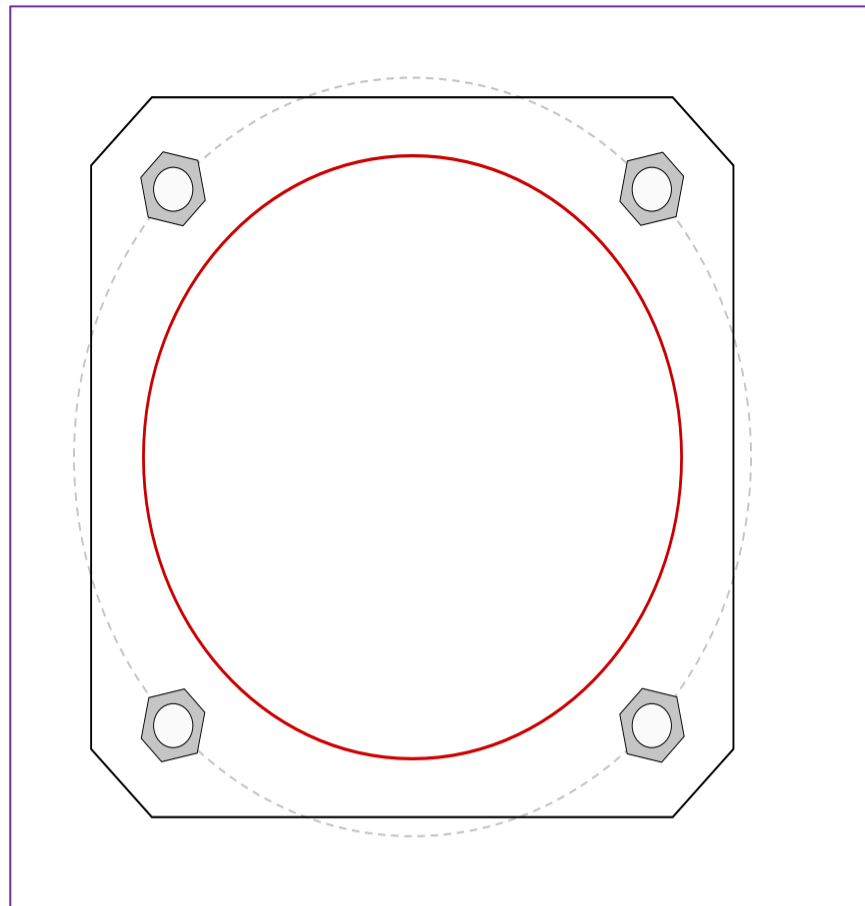

Connection Properties	Analysis Results
-----------------------	------------------

Anchor Rod Data
(4) 2-1/4" ϕ bolts (A615-75 N; $F_y=75$ ksi, $F_u=100$ ksi) on 39" BC
Base Plate Data
37" W x 2" Plate (A572-50; $F_y=50$ ksi, $F_u=65$ ksi); Clip: 3.5 in
Stiffener Data
N/A
Pole Data
31" x 0.3125" 12-sided pole (A572-65; $F_y=65$ ksi, $F_u=80$ ksi)

Anchor Rod Summary		<i>(units of kips, kip-in)</i>
$P_{u,t} = 185.64$	$\phi P_{n,t} = 243.75$	Stress Rating
$V_u = 3.18$	$\phi V_n = 149.1$	72.5%
$M_u = n/a$	$\phi M_n = n/a$	Pass
Base Plate Summary		
Max Stress (ksi):	36.47	(Flexural)
Allowable Stress (ksi):	45	
Stress Rating:	77.2%	Pass

Monopole Base Plate Connection - Seismic



Site Info	
BU #	815558
Site Name	NOVATO
Order #	690637 Rev. 0

Analysis Considerations	
TIA-222 Revision	H
Grout Considered:	No
l_{ar} (in)	0.25

Applied Loads	
Moment (kip-ft)	332.82
Axial Force (kips)	21.12
Shear Force (kips)	6.02

*TIA-222-H Section 15.5 Applied

*1.5 Overstrength Factor Applied

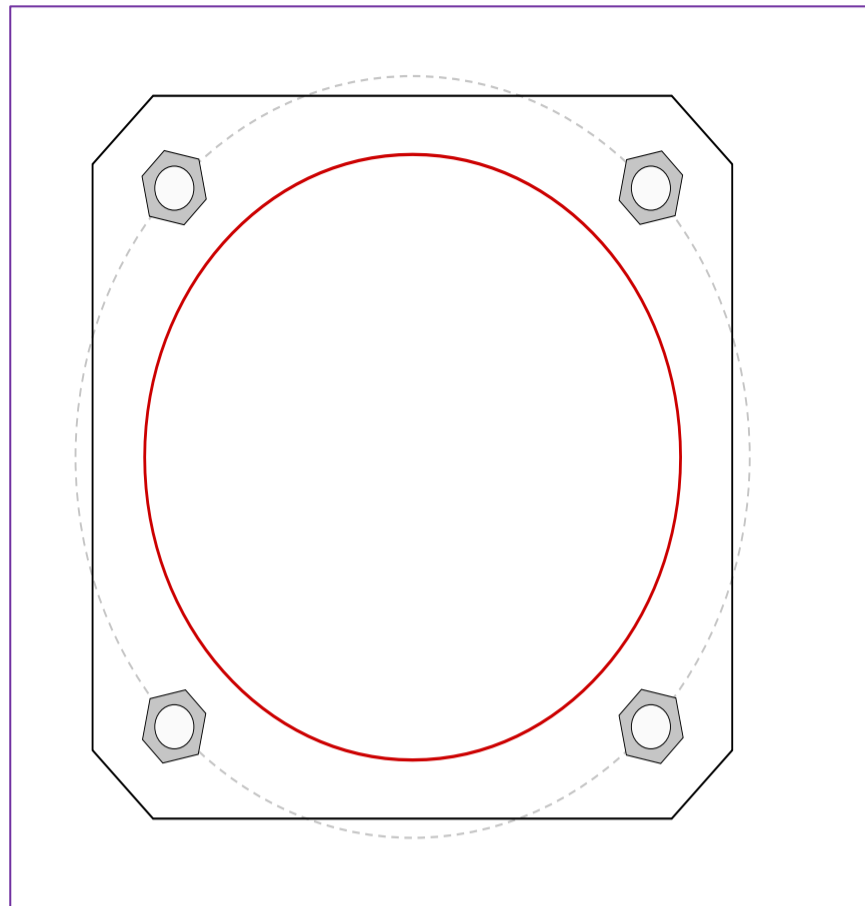

Connection Properties	Analysis Results
-----------------------	------------------

Anchor Rod Data
(4) 2-1/4" ϕ bolts (A615-75 N; $F_y=75$ ksi, $F_u=100$ ksi) on 39" BC
Base Plate Data
37" W x 2" Plate (A572-50; $F_y=50$ ksi, $F_u=65$ ksi); Clip: 3.5 in
Stiffener Data
N/A
Pole Data
31" x 0.3125" 12-sided pole (A572-65; $F_y=65$ ksi, $F_u=80$ ksi)

Anchor Rod Summary		<i>(units of kips, kip-in)</i>
$P_{u,t} = 148.12$	$\phi P_{n,t} = 243.75$	Stress Rating
$V_u = 2.26$	$\phi V_n = 149.1$	57.9%
$M_u = n/a$	$\phi M_n = n/a$	Pass
Base Plate Summary		
Max Stress (ksi):	20.17	(Flexural)
Allowable Stress (ksi):	45	
Stress Rating:	42.7%	Pass

Drilled Pier Foundation

BU # :	815558
Site Name:	NOVATO
Order Number:	690637 Rev. 0
TIA-222 Revision:	H
Tower Type:	Monopole



Applied Loads		
	Comp.	Uplift
Moment (kip-ft)	618.45	
Axial Force (kips)	17.6	
Shear Force (kips)	12.72	

Material Properties		
Concrete Strength, f'c:	3	ksi
Rebar Strength, Fy:	60	ksi
Tie Yield Strength, Fyt:	40	ksi

Pier Design Data		
Depth	17.25	ft
Ext. Above Grade	1	ft
Pier Section 1		
<i>From 1' above grade to 17.25' below grade</i>		
Pier Diameter	5	ft
Rebar Quantity	14	
Rebar Size	8	
Clear Cover to Ties	5	in
Tie Size	4	
Tie Spacing		in

Rebar & Pier Options
 Embedded Pole Inputs
 Belled Pier Inputs

Analysis Results		
Soil Lateral Check		
	Compression	Uplift
D _{v=0} (ft from TOC)	5.68	-
Soil Safety Factor	2.84	-
Max Moment (kip-ft)	678.70	-
Rating*	44.6%	-
Soil Vertical Check		
	Compression	Uplift
Skin Friction (kips)	132.26	-
End Bearing (kips)	235.62	-
Weight of Concrete (kips)	64.50	-
Total Capacity (kips)	367.88	-
Axial (kips)	82.10	-
Rating*	21.3%	-
Reinforced Concrete Flexure		
	Compression	Uplift
Critical Depth (ft from TOC)	5.61	-
Critical Moment (kip-ft)	678.68	-
Critical Moment Capacity	1278.73	-
Rating*	50.5%	-
Reinforced Concrete Shear		
	Compression	Uplift
Critical Depth (ft from TOC)	13.67	-
Critical Shear (kip)	116.80	-
Critical Shear Capacity	270.08	-
Rating*	41.2%	-

Structural Foundation Rating*	50.5%
Soil Interaction Rating*	44.6%

*Rating per TIA-222-H Section 15.5

Check Limitation	
Apply TIA-222-H Section 15.5:	<input checked="" type="checkbox"/>
N/A	<input type="checkbox"/>
Design Options	
Input Effective Depths (else Actual):	<input type="checkbox"/>
Consider non-tapered moment capacity:	<input type="checkbox"/>
Check Shear along Depth of Pier:	<input checked="" type="checkbox"/>
Utilize Shear-Friction Methodology:	<input type="checkbox"/>
Override Critical Depth:	<input type="checkbox"/>

[Go to Soil Calculations](#)

Soil Profile			
Groundwater Depth	N/A	# of Layers	2

Layer	Top (ft)	Bottom (ft)	Thickness (ft)	γ _{soil} (pcf)	γ _{concrete} (pcf)	Cohesion (ksf)	Angle of Friction (degrees)	Calculated Ultimate Skin Friction Comp (ksf)	Calculated Ultimate Skin Friction Uplift (ksf)	Ultimate Skin Friction Comp Override (ksf)	Ultimate Skin Friction Uplift Override (ksf)	Ult. Gross Bearing Capacity (ksf)	SPT Blow Count	Soil Type
1	0	2.5	2.5	100	150	0	0	0.000	0.000	0.00	0.00			Cohesionless
2	2.5	17.25	14.75	110	150	0	30	0.761	0.761			16	10	Cohesionless



BU: 815558
 WO: 2377876
 Order: 690637

Structure: A
 Rev: 0

Location

	Decimal Degrees	Deg	Min	Sec
Lat:	38.112697	+ 38	6	45.71
Long:	-122.549700	- 122	32	58.92

Code and Site Parameters

Seismic Design Code:	TIA-222-H-1	
Site Soil:	D (Default)	Default
Risk Category:	II	
<u>USGS Seismic Reference</u>		
S _s :	1.5000	g
S ₁ :	0.6000	g
T _L :	12	s

Seismic Design Category Determination

Importance Factor, I _e :	1	
Acceleration-based site coefficient, F _a :	1.2000	
Velocity-based site coefficient, F _v :	1.7000	
Design spectral response acceleration short period, S _{DS} :	1.2000	g
Design spectral response acceleration 1 s period, S _{D1} :	0.6800	g
T _s :	0.5667	s
Seismic Design Category Based on S _{DS} :	D	
Seismic Design Category Based on S _{D1} :	D	
Seismic Design Category Based on S ₁ :	N/A	
Controlling Seismic Design Category:	D	



BU: 815558
 WO: 2377876
 Order: 690637

Structure: A
 Rev: 0

Tower Details

Tower Type:	Tapered Monopole	
Height, h:	65.9	ft
Effective Seismic Weight, W:	14.66	kips
Amplification Factor, A _s :	1.0	2.7.8.1

Seismic Base Shear

Response Modification Factor, R:	1.5	
Discrete Appurtenance Weight in Top 1/3 of Structure, W _U :	7.261688	kips
W _L :	7.400119456	kips
E:	29000.0	ksi
g:	386.088	in/s ²
Average Moment of Inertia, I _{avg} :	1910.886702	in ⁴
F _a :	0.604120257	hz
Approximate Fundamental Period Monopole, T _a :	1.6553	s
		2.7.7.1.3.3
Seismic Response Coefficient, C _s :	0.4108	Table 2-12 Note 3
Seismic Response Coefficient Max 1, C _{smax}	N/A	
Seismic Response Coefficient Max 2, C _{smax}	N/A	
Seismic Response Coefficient Min 1, C _{smin}	0.0528	2.7.7.1.1
Seismic Response Coefficient Min 2, C _{smin}	0.3200	2.7.7.1.1
Controlling Seismic Response Coefficient, C _{sc}	0.4108	
Seismic Base Shear, V	6.023	kips
		2.7.7.1.1

Vertical Distribution Factors

Period Related Exponent, k:	1.578
Sum of w _i h _i ^k	6103.56

Tower Section Loads								
Section Number	Length	Top Height	Mid Height, h_x	Section Weight, w_x	$w_x h_x^k$	C_{vx}	F_{xh}	F_{xv}
1 - 1	4.20	65.90	63.80	0.2200	154.80	0.0254	0.1528	0.0528
1 - 2	10.00	61.70	56.70	0.5606	327.49	0.0537	0.3232	0.1345
1 - 3	10.00	51.70	46.70	0.6125	263.45	0.0432	0.2600	0.1470
1 - 4	10.00	41.70	36.70	0.6644	195.39	0.0320	0.1928	0.1594
2 - 1	4.89	34.89	32.44	0.4099	99.23	0.0163	0.0979	0.0984
2 - 2	10.00	30.00	25.00	0.8871	142.38	0.0233	0.1405	0.2129
2 - 3	10.00	20.00	15.00	0.9520	68.25	0.0112	0.0673	0.2285
2 - 4	10.00	10.00	5.00	1.0168	12.88	0.0021	0.0127	0.2440
Sum				5.3232	1263.86			

Discrete Loads						
Name	h_x	w_x	$w_x h_x^k$	C_{vx}	F_{xh}	F_{xv}
kathrein 742 215 w/ Mount Pipe	56.00	0.0331	18.97	0.0031	0.0187	0.0079
tower mounts Side Arm Mount [SO 102-3]	56.00	0.0750	42.96	0.0070	0.0424	0.0180
jma wireless MX08FRO665-21	49.00	0.0825	38.28	0.0063	0.0378	0.0198
jma wireless MX08FRO665-21	49.00	0.0825	38.28	0.0063	0.0378	0.0198
jma wireless MX08FRO665-21	49.00	0.0825	38.28	0.0063	0.0378	0.0198
fujitsu TA08025-B604	49.00	0.0640	29.70	0.0049	0.0293	0.0154
fujitsu TA08025-B604	49.00	0.0640	29.70	0.0049	0.0293	0.0154
fujitsu TA08025-B604	49.00	0.0640	29.70	0.0049	0.0293	0.0154
raycap RDIDC-9181-PF-48	49.00	0.0220	10.21	0.0017	0.0101	0.0053
fujitsu TA08025-B605	49.00	0.0750	34.80	0.0057	0.0343	0.0180
fujitsu TA08025-B605	49.00	0.0750	34.80	0.0057	0.0343	0.0180
fujitsu TA08025-B605	49.00	0.0750	34.80	0.0057	0.0343	0.0180
Commscope MC-PK8-DSH	49.00	1.8016	835.96	0.1370	0.8249	0.4324
(2) ubiquiti network AM-5G19-120 w/ Mount Pipe	39.00	0.0500	16.19	0.0027	0.0160	0.0120
(2) ubiquiti network AM-5G19-120 w/ Mount Pipe	39.00	0.0500	16.19	0.0027	0.0160	0.0120
(2) mikrotik NETMETAL AC2	39.00	0.0040	1.29	0.0002	0.0013	0.0010
(3) mikrotik NETMETAL AC2	39.00	0.0060	1.94	0.0003	0.0019	0.0014
(3) mikrotik NETMETAL AC2	39.00	0.0060	1.94	0.0003	0.0019	0.0014
(2) tower mounts 8' x 2" Mount Pipe	39.00	0.0580	18.77	0.0031	0.0185	0.0139
(2) tower mounts 8' x 2" Mount Pipe	39.00	0.0580	18.77	0.0031	0.0185	0.0139
(2) tower mounts 8' x 2" Mount Pipe	39.00	0.0580	18.77	0.0031	0.0185	0.0139
Site Pro 1 RMV12-396	39.00	0.7743	250.64	0.0411	0.2473	0.1858
kathrein 742 215 w/ Mount Pipe	19.00	0.0331	3.45	0.0006	0.0034	0.0079
kathrein 742 215 w/ Mount Pipe	19.00	0.0331	3.45	0.0006	0.0034	0.0079
tower mounts Side Arm Mount [SO 102-3]	19.00	0.0750	7.81	0.0013	0.0077	0.0180
matsing MS-MBA-3.2-H4-L4 w/ Mount Pipe	61.00	0.1556	102.00	0.0167	0.1007	0.0373
cambridge broadband networks group 39GHz VectaStar w/ Mount Pipe	61.00	0.0490	32.12	0.0053	0.0317	0.0118
commscope NHH-33B-R2B w/ Mount Pipe	61.00	0.1345	88.17	0.0144	0.0870	0.0323
ericsson AIR 6449 B77D_CCIV3 w/ Mount Pipe	61.00	0.1098	71.97	0.0118	0.0710	0.0263
commscope NHH-33B-R2B w/ Mount Pipe	61.00	0.1345	88.17	0.0144	0.0870	0.0323
ericsson AIR 6449 B77D_CCIV3 w/ Mount Pipe	61.00	0.1098	71.97	0.0118	0.0710	0.0263
cambridge broadband networks group 39GHz VectaStar w/ Mount Pipe	61.00	0.0490	32.12	0.0053	0.0317	0.0118
ericsson AIR 6449 B77D_CCIV3 w/ Mount Pipe	61.00	0.1098	71.97	0.0118	0.0710	0.0263
matsing MS-MBA-3.2-H4-L4 w/ Mount Pipe	61.00	0.1556	102.00	0.0167	0.1007	0.0373
commscope NHH-33B-R2B w/ Mount Pipe	61.00	0.1345	88.17	0.0144	0.0870	0.0323
cambridge broadband networks group 39GHz VectaStar w/ Mount Pipe	61.00	0.0490	32.12	0.0053	0.0317	0.0118
commscope NHH-33B-R2B w/ Mount Pipe	61.00	0.1345	88.17	0.0144	0.0870	0.0323
cambridge broadband networks group 39GHz VectaStar w/ Mount Pipe	61.00	0.0490	32.12	0.0053	0.0317	0.0118
ericsson 4449	61.00	0.0710	46.55	0.0076	0.0459	0.0170
raycap RCMDC-3315-PF-48	61.00	0.0320	20.98	0.0034	0.0207	0.0077
(6) commscope CBC1923T-DS-43	61.00	0.0480	31.47	0.0052	0.0311	0.0115
ericsson 8843	61.00	0.0720	47.20	0.0077	0.0466	0.0173
ericsson 8843	61.00	0.0720	47.20	0.0077	0.0466	0.0173
(2) ericsson 8843	61.00	0.1440	94.40	0.0155	0.0932	0.0346
raycap RCMDC-3315-PF-48	61.00	0.0320	20.98	0.0034	0.0207	0.0077
ericsson 4449	61.00	0.0710	46.55	0.0076	0.0459	0.0170
commscope CBC1923T-DS-43	61.00	0.0080	5.24	0.0009	0.0052	0.0019
(2) ericsson 4449	61.00	0.1420	93.09	0.0153	0.0919	0.0341
(2) ericsson 8843	61.00	0.1440	94.40	0.0155	0.0932	0.0346
(5) commscope CBC1923T-DS-43	61.00	0.0400	26.22	0.0043	0.0259	0.0096
(2) ericsson 8843	61.00	0.1440	94.40	0.0155	0.0932	0.0346
ericsson 4449	61.00	0.0710	46.55	0.0076	0.0459	0.0170
ericsson 4449	61.00	0.0710	46.55	0.0076	0.0459	0.0170
(4) tower mounts T-Arm Mount [TA 601-1]	61.00	0.9680	634.60	0.1040	0.6262	0.2323
(2) tower mounts T-Arm Mount [TA 601-1]	61.00	0.4840	317.30	0.0520	0.3131	0.1162
(2) tower mounts T-Arm Mount [TA 601-1]	61.00	0.4840	317.30	0.0520	0.3131	0.1162
(2) tower mounts 8'X2" Horizontal Pipe	61.00	0.0500	32.78	0.0054	0.0323	0.0120
tower mounts 8'X2" Horizontal Pipe	61.00	0.0250	16.39	0.0027	0.0162	0.0060
tower mounts 8'X2" Horizontal Pipe	61.00	0.0250	16.39	0.0027	0.0162	0.0060
tower mounts 2' x 2" Pipe Mount	61.00	0.0070	4.59	0.0008	0.0045	0.0017
(4) tower mounts 2' x 2" Pipe Mount	61.00	0.0280	18.36	0.0030	0.0181	0.0067
tower mounts 8' x 2" Mount Pipe	61.00	0.0290	19.01	0.0031	0.0188	0.0070
tower mounts 8' x 2" Mount Pipe	61.00	0.0290	19.01	0.0031	0.0188	0.0070
ubiquiti network RD-5G30	39.00	0.0220	7.12	0.0012	0.0070	0.0053
ubiquiti network RD-5G30	39.00	0.0220	7.12	0.0012	0.0070	0.0053
ubiquiti network RD-5G30	39.00	0.0220	7.12	0.0012	0.0070	0.0053
ubiquiti network RD-5G30	39.00	0.0220	7.12	0.0012	0.0070	0.0053
Sum		8.5552	4662.76			

Linear Loads								
Name	Start Height	End Height	h_x	w_x	$w_x h_x^k$	C_{vx}	F_{xh}	F_{xv}
(20) andrew LDF5-50A(7/8) From 0 to 61	55.90	61.00	58.45	0.0337	20.63	0.0034	0.0204	0.0081
(20) andrew LDF5-50A(7/8) From 0 to 61	45.90	55.90	50.90	0.0660	32.52	0.0053	0.0321	0.0158
(20) andrew LDF5-50A(7/8) From 0 to 61	35.90	45.90	40.90	0.0660	23.03	0.0038	0.0227	0.0158
(20) andrew LDF5-50A(7/8) From 0 to 61	25.90	35.90	30.90	0.0660	14.80	0.0024	0.0146	0.0158
(20) andrew LDF5-50A(7/8) From 0 to 61	15.90	25.90	20.90	0.0660	7.98	0.0013	0.0079	0.0158
(20) andrew LDF5-50A(7/8) From 0 to 61	5.90	15.90	10.90	0.0660	2.86	0.0005	0.0028	0.0158
(20) andrew LDF5-50A(7/8) From 0 to 61	0.00	5.90	2.95	0.0389	0.21	0.0000	0.0002	0.0093
(2) commscope RFA1608-16S26-XXX(1-1/4) From 0 to 61	55.90	61.00	58.45	0.0134	8.19	0.0013	0.0081	0.0032
(2) commscope RFA1608-16S26-XXX(1-1/4) From 0 to 61	45.90	55.90	50.90	0.0262	12.91	0.0021	0.0127	0.0063
(2) commscope RFA1608-16S26-XXX(1-1/4) From 0 to 61	35.90	45.90	40.90	0.0262	9.14	0.0015	0.0090	0.0063
(2) commscope RFA1608-16S26-XXX(1-1/4) From 0 to 61	25.90	35.90	30.90	0.0262	5.87	0.0010	0.0058	0.0063
(2) commscope RFA1608-16S26-XXX(1-1/4) From 0 to 61	15.90	25.90	20.90	0.0262	3.17	0.0005	0.0031	0.0063
(2) commscope RFA1608-16S26-XXX(1-1/4) From 0 to 61	5.90	15.90	10.90	0.0262	1.14	0.0002	0.0011	0.0063
(2) commscope RFA1608-16S26-XXX(1-1/4) From 0 to 61	0.00	5.90	2.95	0.0155	0.09	0.0000	0.0001	0.0037
(2) andrew LDF5-50A(7/8) From 0 to 56	55.90	56.00	55.95	0.0001	0.04	0.0000	0.0000	0.0000
(2) andrew LDF5-50A(7/8) From 0 to 56	45.90	55.90	50.90	0.0066	3.25	0.0005	0.0032	0.0016
(2) andrew LDF5-50A(7/8) From 0 to 56	35.90	45.90	40.90	0.0066	2.30	0.0004	0.0023	0.0016
(2) andrew LDF5-50A(7/8) From 0 to 56	25.90	35.90	30.90	0.0066	1.48	0.0002	0.0015	0.0016
(2) andrew LDF5-50A(7/8) From 0 to 56	15.90	25.90	20.90	0.0066	0.80	0.0001	0.0008	0.0016
(2) andrew LDF5-50A(7/8) From 0 to 56	5.90	15.90	10.90	0.0066	0.29	0.0000	0.0003	0.0016
(2) andrew LDF5-50A(7/8) From 0 to 56	0.00	5.90	2.95	0.0039	0.02	0.0000	0.0000	0.0009
cui CU12PSM9P8XXX(1-3/8) From 0 to 49	45.90	49.00	47.45	0.0051	2.27	0.0004	0.0022	0.0012
cui CU12PSM9P8XXX(1-3/8) From 0 to 49	35.90	45.90	40.90	0.0166	5.79	0.0009	0.0057	0.0040
cui CU12PSM9P8XXX(1-3/8) From 0 to 49	25.90	35.90	30.90	0.0166	3.72	0.0006	0.0037	0.0040
cui CU12PSM9P8XXX(1-3/8) From 0 to 49	15.90	25.90	20.90	0.0166	2.01	0.0003	0.0020	0.0040
cui CU12PSM9P8XXX(1-3/8) From 0 to 49	5.90	15.90	10.90	0.0166	0.72	0.0001	0.0007	0.0040
cui CU12PSM9P8XXX(1-3/8) From 0 to 49	0.00	5.90	2.95	0.0098	0.05	0.0000	0.0001	0.0024
(8) alcatel lucent CAT5E(1/4) From 0 to 39	35.90	39.00	37.45	0.0011	0.35	0.0001	0.0003	0.0003
(8) alcatel lucent CAT5E(1/4) From 0 to 39	25.90	35.90	30.90	0.0037	0.83	0.0001	0.0008	0.0009
(8) alcatel lucent CAT5E(1/4) From 0 to 39	15.90	25.90	20.90	0.0037	0.45	0.0001	0.0004	0.0009
(8) alcatel lucent CAT5E(1/4) From 0 to 39	5.90	15.90	10.90	0.0037	0.16	0.0000	0.0002	0.0009
(8) alcatel lucent CAT5E(1/4) From 0 to 39	0.00	5.90	2.95	0.0022	0.01	0.0000	0.0000	0.0005
(9) andrew LDF4-50A(1/2) From 0 to 19	15.90	19.00	17.45	0.0042	0.38	0.0001	0.0004	0.0010
(9) andrew LDF4-50A(1/2) From 0 to 19	5.90	15.90	10.90	0.0135	0.58	0.0001	0.0006	0.0032
(9) andrew LDF4-50A(1/2) From 0 to 19	0.00	5.90	2.95	0.0080	0.04	0.0000	0.0000	0.0019
(4) andrew LDF5-50A(7/8) From 0 to 19	15.90	19.00	17.45	0.0041	0.37	0.0001	0.0004	0.0010
(4) andrew LDF5-50A(7/8) From 0 to 19	5.90	15.90	10.90	0.0132	0.57	0.0001	0.0006	0.0032
(4) andrew LDF5-50A(7/8) From 0 to 19	0.00	5.90	2.95	0.0078	0.04	0.0000	0.0000	0.0019
(4) andrew LDF4-50A(1/2) From 0 to 19	15.90	19.00	17.45	0.0019	0.17	0.0000	0.0002	0.0004
(4) andrew LDF4-50A(1/2) From 0 to 19	5.90	15.90	10.90	0.0060	0.26	0.0000	0.0003	0.0014
(4) andrew LDF4-50A(1/2) From 0 to 19	0.00	5.90	2.95	0.0035	0.02	0.0000	0.0000	0.0008
misc Safety Line 5/8 From 0 to 65.5	55.90	65.50	60.70	0.0038	2.50	0.0004	0.0025	0.0009
misc Safety Line 5/8 From 0 to 65.5	45.90	55.90	50.90	0.0040	1.97	0.0003	0.0019	0.0010
misc Safety Line 5/8 From 0 to 65.5	35.90	45.90	40.90	0.0040	1.40	0.0002	0.0014	0.0010
misc Safety Line 5/8 From 0 to 65.5	25.90	35.90	30.90	0.0040	0.90	0.0001	0.0009	0.0010
misc Safety Line 5/8 From 0 to 65.5	15.90	25.90	20.90	0.0040	0.48	0.0001	0.0005	0.0010
misc Safety Line 5/8 From 0 to 65.5	5.90	15.90	10.90	0.0040	0.17	0.0000	0.0002	0.0010
misc Safety Line 5/8 From 0 to 65.5	0.00	5.90	2.95	0.0024	0.01	0.0000	0.0000	0.0006
Sum					0.7834		176.95	

ASCE Hazards Report

Address:
No Address at This Location

Standard: ASCE/SEI 7-16
Risk Category: II
Soil Class: D - Default (see Section 11.4.3)

Latitude: 38.112697
Longitude: -122.5497
Elevation: 438.9175295178014 ft (NAVD 88)

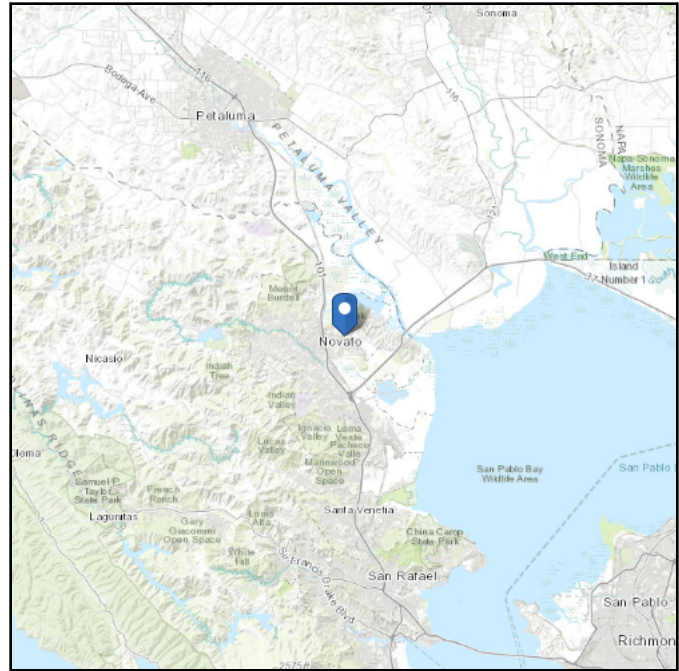
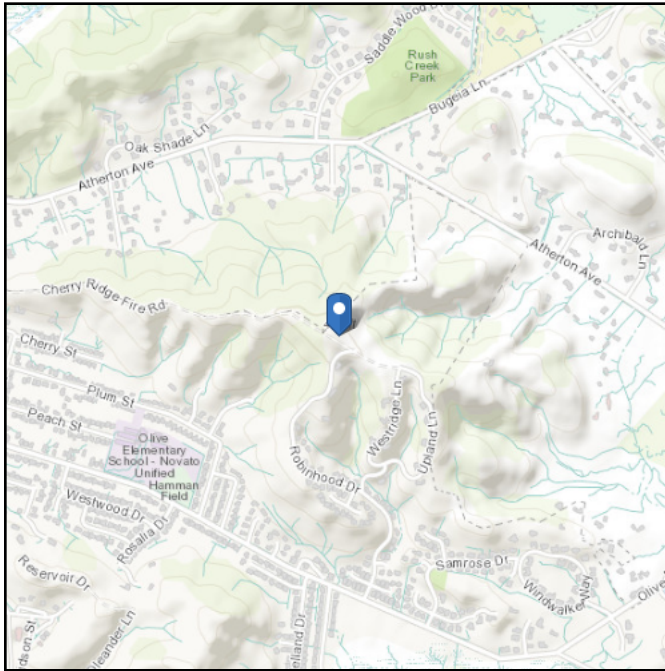

Wind

Results:

Wind Speed	92 Vmph
10-year MRI	64 Vmph
25-year MRI	70 Vmph
50-year MRI	74 Vmph
100-year MRI	79 Vmph

Data Source: ASCE/SEI 7-16, Fig. 26.5-1B and Figs. CC.2-1–CC.2-4, and Section 26.5.2
Date Accessed: Mon Apr 07 2025

Value provided is 3-second gust wind speeds at 33 ft above ground for Exposure C Category, based on linear interpolation between contours. Wind speeds are interpolated in accordance with the 7-16 Standard. Wind speeds correspond to approximately a 7% probability of exceedance in 50 years (annual exceedance probability = 0.00143, MRI = 700 years).

Site is not in a hurricane-prone region as defined in ASCE/SEI 7-16 Section 26.2.

Site Soil Class: D - Default (see Section 11.4.3)

Results:

S_s :	1.5	S_{D1} :	N/A
S_1 :	0.6	T_L :	12
F_a :	1.2	PGA :	0.614
F_v :	N/A	PGA _M :	0.736
S_{MS} :	1.8	F_{PGA} :	1.2
S_{M1} :	N/A	I_e :	1
S_{DS} :	1.2	C_v :	1.4

Ground motion hazard analysis may be required. See ASCE/SEI 7-16 Section 11.4.8.

Data Accessed: Mon Apr 07 2025

Date Source: [USGS Seismic Design Maps](#)

Ice

Results:

Ice Thickness: 0 in.
Concurrent Temperature: 25 F
Gust Speed 30 mph

Data Source: Standard ASCE/SEI 7-16, Figs. 10-2 through 10-8

Date Accessed: Mon Apr 07 2025

Ice thicknesses on structures in exposed locations at elevations higher than the surrounding terrain and in valleys and gorges may exceed the mapped values.

Values provided are equivalent radial ice thicknesses due to freezing rain with concurrent 3-second gust speeds, for a 500-year mean recurrence interval, and temperatures concurrent with ice thicknesses due to freezing rain. Thicknesses for ice accretions caused by other sources shall be obtained from local meteorological studies. Ice thicknesses in exposed locations at elevations higher than the surrounding terrain and in valleys and gorges may exceed the mapped values.

The ASCE Hazard Tool is provided for your convenience, for informational purposes only, and is provided "as is" and without warranties of any kind. The location data included herein has been obtained from information developed, produced, and maintained by third party providers; or has been extrapolated from maps incorporated in the ASCE standard. While ASCE has made every effort to use data obtained from reliable sources or methodologies, ASCE does not make any representations or warranties as to the accuracy, completeness, reliability, currency, or quality of any data provided herein. Any third-party links provided by this Tool should not be construed as an endorsement, affiliation, relationship, or sponsorship of such third-party content by or from ASCE.

ASCE does not intend, nor should anyone interpret, the results provided by this Tool to replace the sound judgment of a competent professional, having knowledge and experience in the appropriate field(s) of practice, nor to substitute for the standard of care required of such professionals in interpreting and applying the contents of this Tool or the ASCE standard.

In using this Tool, you expressly assume all risks associated with your use. Under no circumstances shall ASCE or its officers, directors, employees, members, affiliates, or agents be liable to you or any other person for any direct, indirect, special, incidental, or consequential damages arising from or related to your use of, or reliance on, the Tool or any information obtained therein. To the fullest extent permitted by law, you agree to release and hold harmless ASCE from any and all liability of any nature arising out of or resulting from any use of data provided by the ASCE Hazard Tool.